

# RNJet 100/200

Installation manual

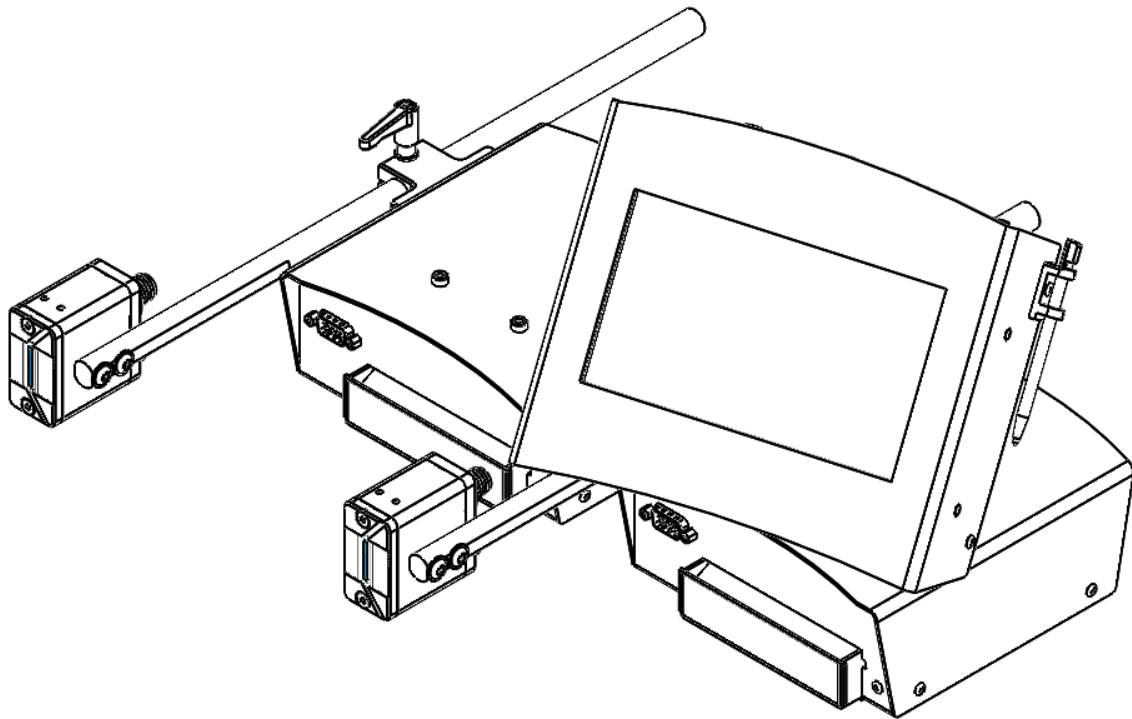



# **RNJet 100/200**

## **Industrial Hi-Resolution Inkjet Printing System**

### **Installation Manual**

Revision 03 11/25/2024

All rights reserved. All trademarks and brand names are the property of their respective owners.

RN MARK INC.

25-16 SIMS CRES. RICHMOND HILL, ON  
L4B 2P1

TEL: +1(905) 597-4977; TF: +1(866) 551-9406; Whatsapp: +1(647) 242-8969

[www.rnmark.com](http://www.rnmark.com)

# Table of Contents

Notices & Cautions .....	1
Safety.....	1
Handling and care .....	1
Ink.....	1
Introduction .....	2
What's in the box.....	2
System specifications .....	3
Operating Temperature:.....	3
Accessories and Consumables.....	5
Ink cartridges and cleaners .....	6
Installation.....	7
Rod Mount .....	7
Printhead.....	8
Ink System.....	9
Rod.....	11
Ink tube.....	11
Controller.....	13
Power Supply .....	14
Data Connections.....	15
Photocell Sensor.....	15
Shaft Encoder.....	18
USB.....	19
Ethernet.....	19
External Alarm Terminal (Cartridge Ink System only) .....	20
Ink Data .....	20
Serial Port (RS-232) .....	21
Print Head Ports.....	21
Start-up.....	24
Adjusting.....	24

Adjusting the Slider Clamp.....	24
Adjusting the Printhead.....	24
Printer Head Positions.....	27
Horizontal.....	27
Skyscraper.....	27
Down-shooter.....	28
Priming / Purging.....	29
Maintenance and Services.....	31
Cleaning the Printer Head.....	31
Flushing the Print Head.....	32
Changing the printing ink color.....	33
Storage Ink (Maintenance Ink).....	34
Installation and Technical Support.....	35

# Notices & Cautions

## Safety

- During handling, installation, maintenance and operating procedures for the printing system, always follow safety regulations by wearing safety glasses, gloves and protective clothing.
- Keep all print system components and fluids away from open flames and excessive heat.
- In case of fluid eye contact, flush immediately with water and receive appropriate medical attention.
- The power source used for print system should comply with all safety regulations and codes required for safe plugging.
- Power, data and sensor input cables must be inserted appropriately in their respective locations. Where possible, route cables away from moving objects and secure via tie-wraps.

## Handling and care

The printhead engine is encased and the print nozzles are exposed through the nozzle guard. Extra precaution should be taken when handling the printer head during installation, operation and maintenance. Never use abrasive materials on or near the exposed print nozzles.

**Notice:** *Do not allow objects to be in direct contact with the print head's nozzles.*

## Ink

Inks come in different solutions, varieties, and codes (e.g. Oil-based, Solvent Based, UV, etc.), make sure to use identical ink for each printer system and avoid exchange of ink with other varieties.

**Notice:** *For best results, always use RN MARK premium inks.*

# Introduction

## What's in the box

Following are all the components that are included inside the RNJet 100 and 200 packages (see Figure 1). In cases that RNJet 200 require more components; quantities are shown inside the [].

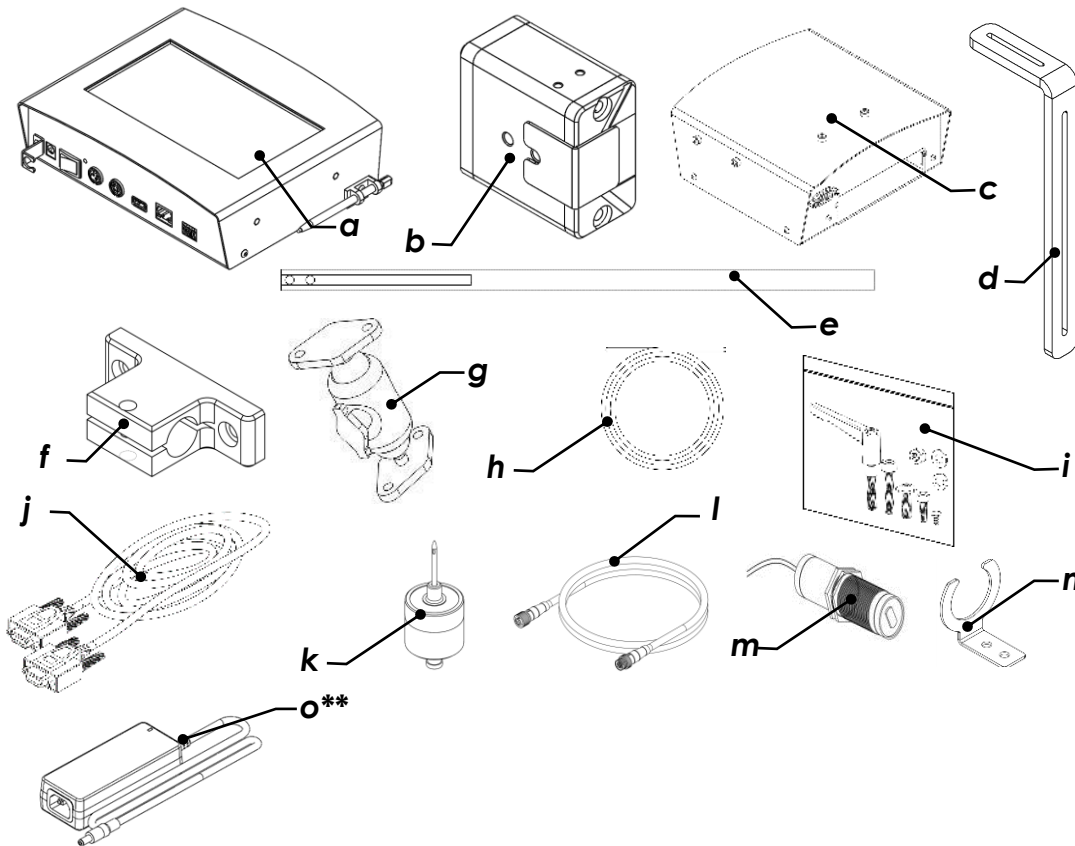

- a:** Controller x 1pc
- b:** Print Head x 1pc [2pcs]
- c:** Ink System x 1pc [2pcs]
- d:** L-shape Mount x 1pc [2pcs]
- e:** Rod x1pc [2pcs]
- f:** Rod Mount x 1pc [2pcs]
- g:** Controller Pivot Mount x 1pc
- h:** Ink Tube x 1pc [2pcs]
- i:** Screw Pack x 1set

- j:** Ink Data Cable x 1pc [2pcs]
- k:** Filter-Needle Assembly x 1pc [2pcs]
- l:** Data Cable x 1pc [2pcs]
- m:** Photocell (Sensor) x 1pc
- n:** Photocell mount x 1pc
- o:** Power adaptor x 1pc\*\*

\* Only for RNJet 200.

\*\* Due to different power plug standards worldwide, we do not supply the power cord.

Figure 1

# System specifications

## General

**Operating Temperature:** 0-45 °C

\* **Speed:** 600 mm/s or 23.6 in/sec

\* **Resolution:** 180 pixels per inch

**Print Height:** 18 mm (0.7") print height [up to 36 mm (1.4"), conditions apply]

**I/O power:** (100-240 V 50/60 Hz 5.0A) / (12 V 60W)

**I/O data:** Ethernet, NPN Sensor input, integrated 7" Touch LCD input, Speed encoder control (shaft encoder)

**Cartridge:** Clean & Sealed ink cartridge

20 million characters per cartridge (based on 85 dots/character)

## Ink-Type Compatibility:

Oil-based inks for porous materials

Solvent-based for non-porous materials (CFIA Approved fast dry inks) and Solvent-based for porous materials.

## Software:

Advanced layout design in RN Soft Windows-based OS (PC)

User-friendly layout design in RN Soft Linux-based OS (Touch LCD)

Dynamic Data Generation

Supports all general graphic input file types & True Type Fonts

## Supported Barcode Types:

1-D: All major 1-D barcode formats such as:

Codabar, Code, EAN, MSI, RSS, UPC, T F, GS1databar, etc.

2-D: QR-Code, ECC200 (Datamatrix), PDF417/macro, Aztec, etc.

## Standards & Certificates:

CE, FCC, CSA, ICES, Lead-free & RoHS compliant

\* These are the default values, refer to user manual for more information if higher speed is required.



**Dimension:**

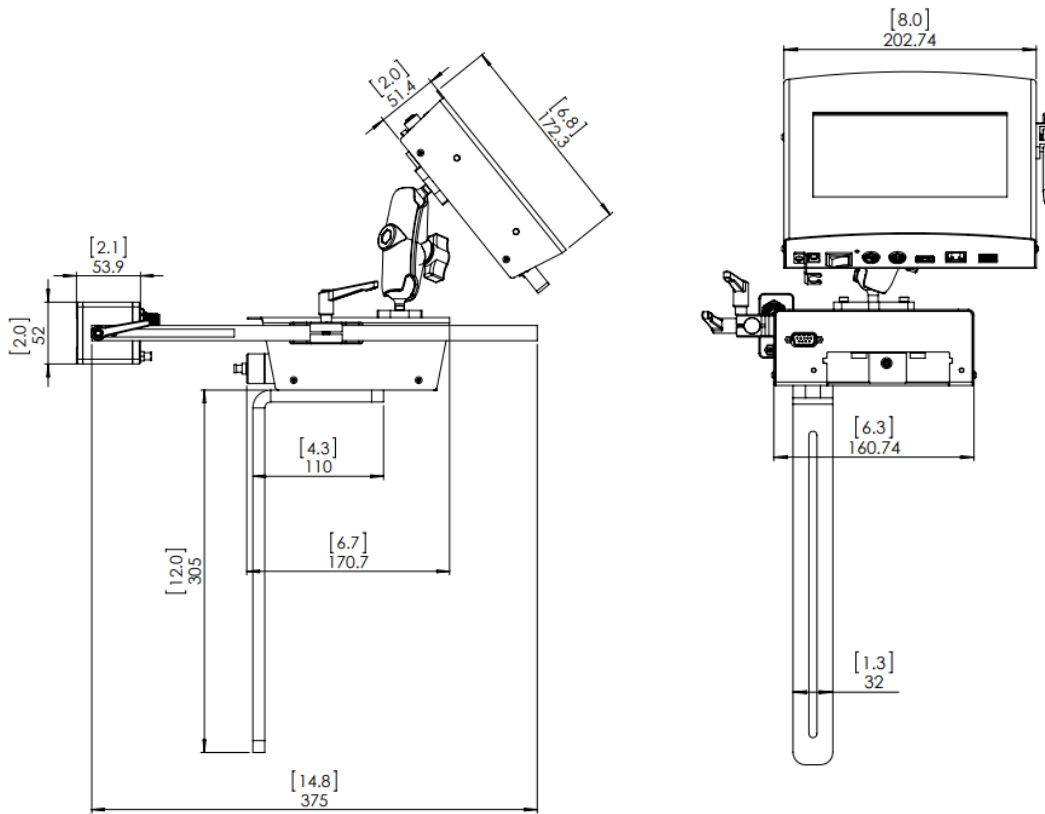

RNJet 200 Configuration\*

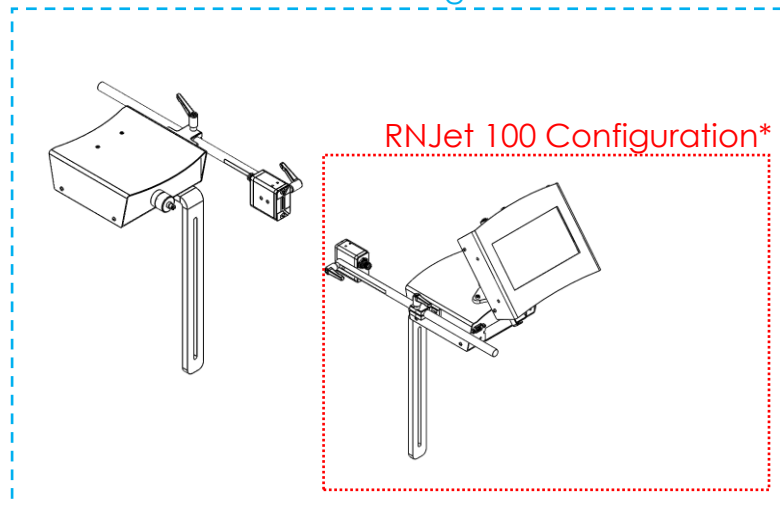

RNJET 100/200\* Dimensions are in mm [inch]

\* RNJet 100, shown in dotted box has only 1X Print head while RNJet200, shown in dashed box has 2X Print heads.

Figure 2

## Accessories and Consumables

Below are optional and essential items your device should have to operate or keep up with the maintenance schedule. (See Figure 3)

You could find more information on accessories and consumables on our website at [www.rnmark.com](http://www.rnmark.com)

**Notice:** Items below are not included in this package and should be ordered separately.

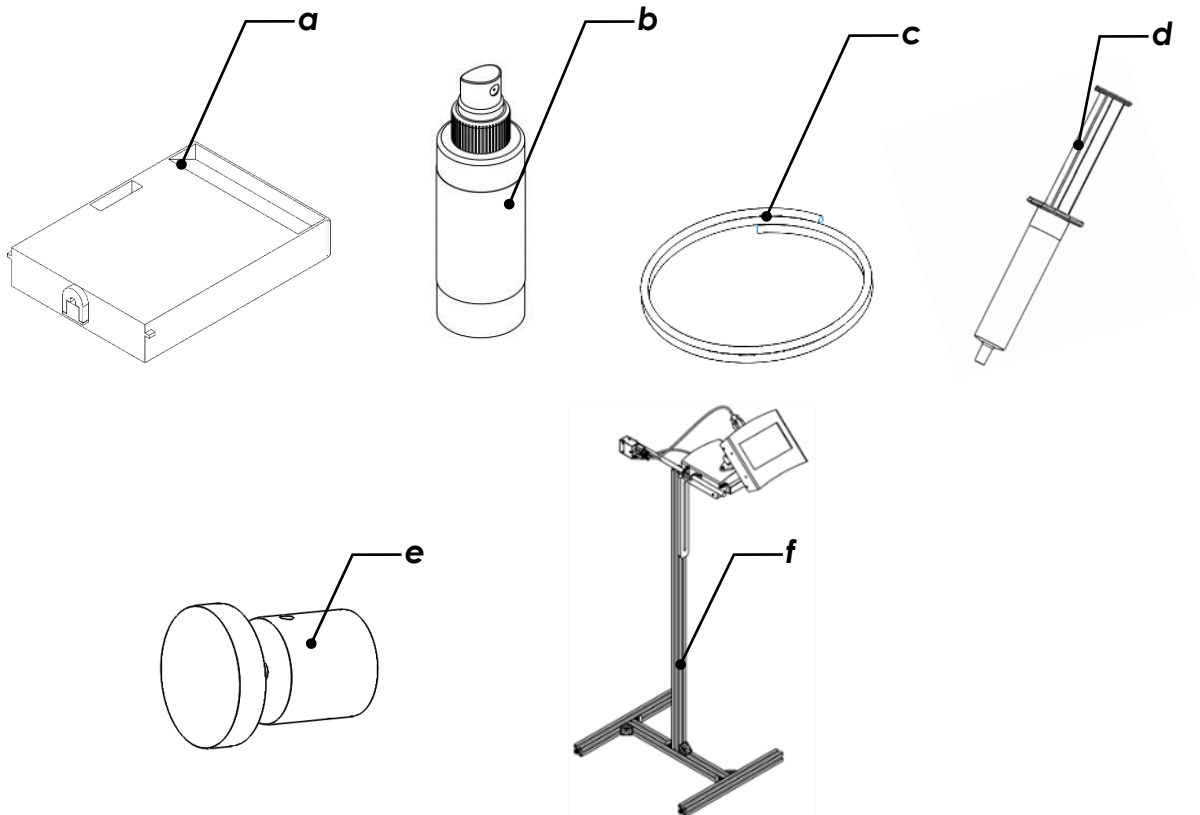

**a:** Ink cartridge

**b:** Cleaner Spray

**e:** Shaft Encoder

**c:** Extra ink tube

**d:** Cleaner syringe

**f:** Portable stands

Figure 3

## Ink cartridges and cleaners

**Notice:** For best results, always use RN MARK premium ink cartridges.

Please refer to list below for purchasing RN MARK premium ink cartridges:

### Solvent-Based Consumables:

Name	Description	Part Number
BSF BLACK-C	Black Solvent-Based Fast Dry Ink Cartridge	100-1609-101
BSF BLACK-E	Black Solvent-Based Slow Dry Ink Cartridge	100-1618-101
BSF BLACK-P	Black Solvent-Based Ink for Porous Material	100-1613-101
BSF RED-P	Red Solvent-Based Ink for Porous Material	100-1613-103
BSF-WHITE	White Solvent-Based Ink Cartridge	100-1602-104
BSF-YELLOW	Yellow Solvent-Based Ink Cartridge	100-1602-105
SC-110	Solvent-Based Cartridge Cleaner	100-1605-108
SC-120	Solvent-Based Spray Cleaner	100-1505-208
MS110-RED	Storage Ink Cartridge	100-1607-103

### Oil-Based Consumables:

Name	Description	Part Number
OIL-BLACK	Black Oil-Based Ink Cartridge	100-1604-101
OC-110	Oil-Based Cartridge Cleaner	100-1606-108
OC-120	Oil-Based Spray Cleaner solution	100-1506-208

For more information, please go to [www.rnmark.com](http://www.rnmark.com)

**Notice:** make sure to use identical ink bases for each printer system and avoid exchange of ink with other varieties. (ex. if you are using solvent-base ink never change to oil-based ink and vice versa)

# Installation

## Rod Mount

Align the rod mount with the ink system as shown in Figure 4 and fasten the 2x M4-12mm.

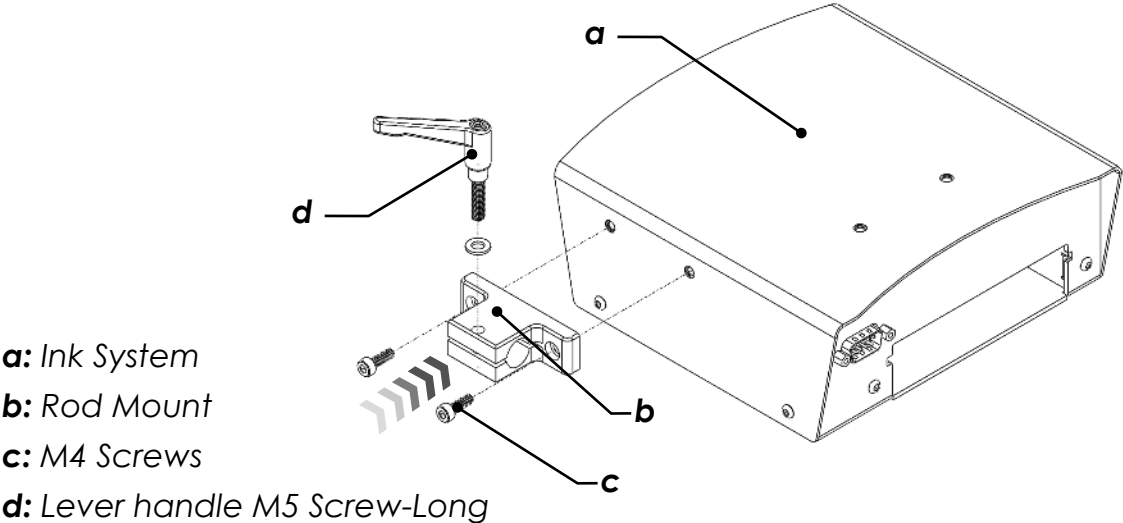

Figure 4

**Notice:** While assembling note that the unthreaded jaw of the rod mount must be on top.

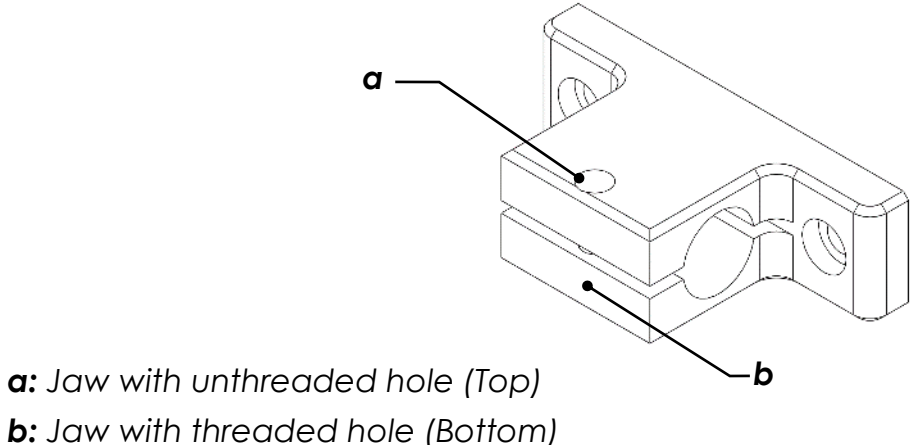

Figure 5

## Printhead

The print head is packed and sealed when taken out of package. To prepare for assembly it must be unsealed. Please do not use sharp tools to open the seal.

**Notice:** the print-head has been tested before product delivery and may contain certain amount of test ink. Unpack carefully as ink spillage may occur.

- Unseal protection wrap from print head.

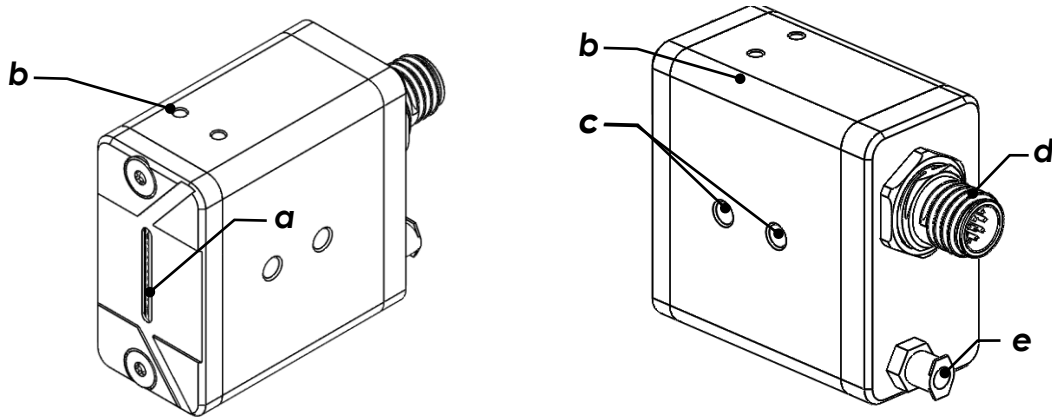

**a:** Nozzles

**b:** M3 Mounting hole(Both sides)

**c:** M5 Mounting hole

**d:** M12 Round Male Pin Connector

**e:** Ink Inlet

Figure 6

**Notice 1:** M12 Round Male Pin connector must be connected to the controller using the provided 2m Male-Female cable (Black).

**Notice 2:** It is recommended to install the print head as shown in **Error! Reference source not found.**, to eliminate risk of electric short due to ink's electrical conductivity in case of ink leakage.

**Notice 3:** Should the printer head need to be shipped or stored, ensure that the exposed print nozzles are protected from damage. Use a lint free material, spray some cleaner solution and put it in front of nozzles and seal the head using stretch wrap.

## Ink System

Installation and positioning the print system is typically unique to each customer. The pre-slotted mount bracket is provided for convenience and is designed for use with the two integrated threaded holes located on the bottom of the ink supply assembly. If you choose not to use it, ensure the ink supply unit is mounted safely and securely attached in a fixed and horizontally leveled position.

- Align the L-shape stand with the two nuts devised on the bottom of the ink system.
- While holding the Ink system, fasten the M5 screws as shown in Figure 7.

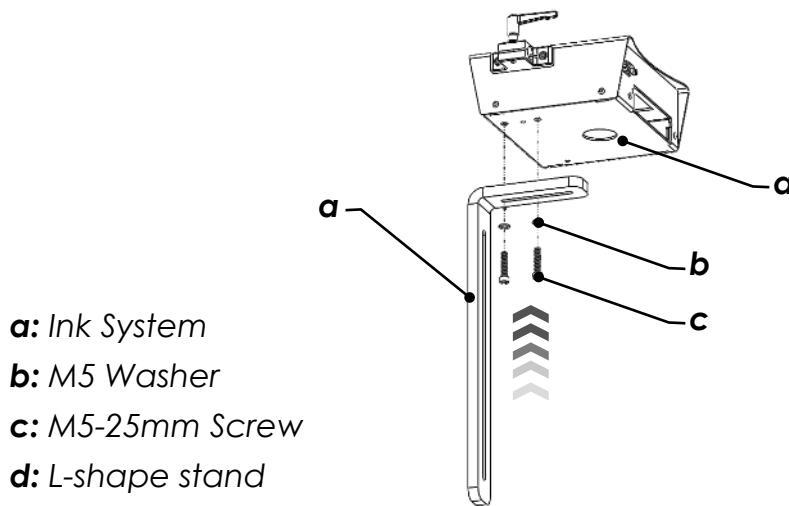
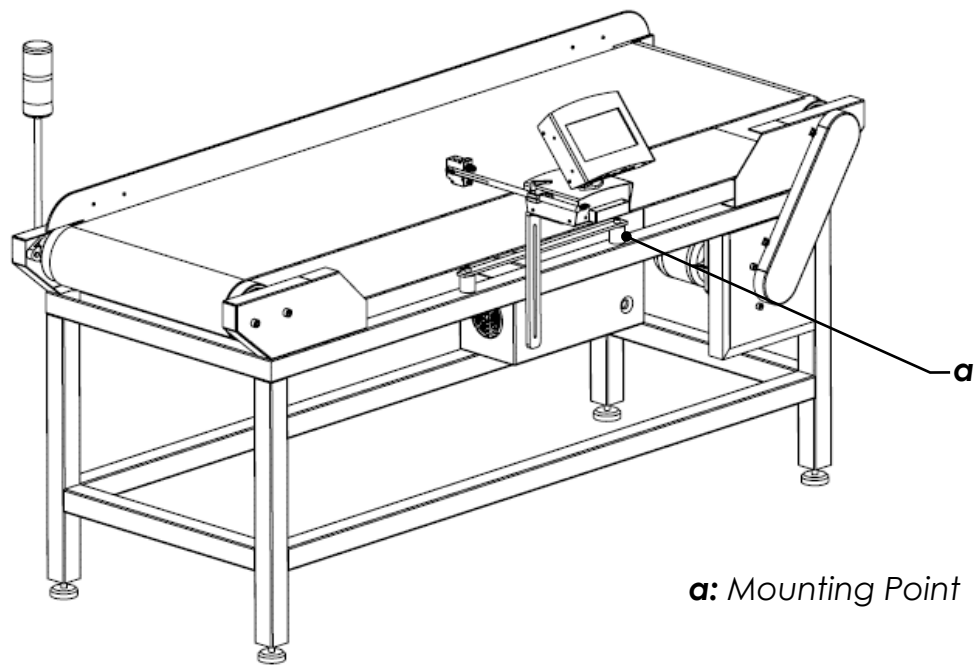

Figure 7

The full assembly can be directly mounted on the belt-conveyor as shown in Figure 8.



**a:** Mounting Point

Figure 8

The printer assembly can also be mounted on a customized stand. Overall height can be adjusted by sliding the L-Shape on the Aluminum bar as shown below.

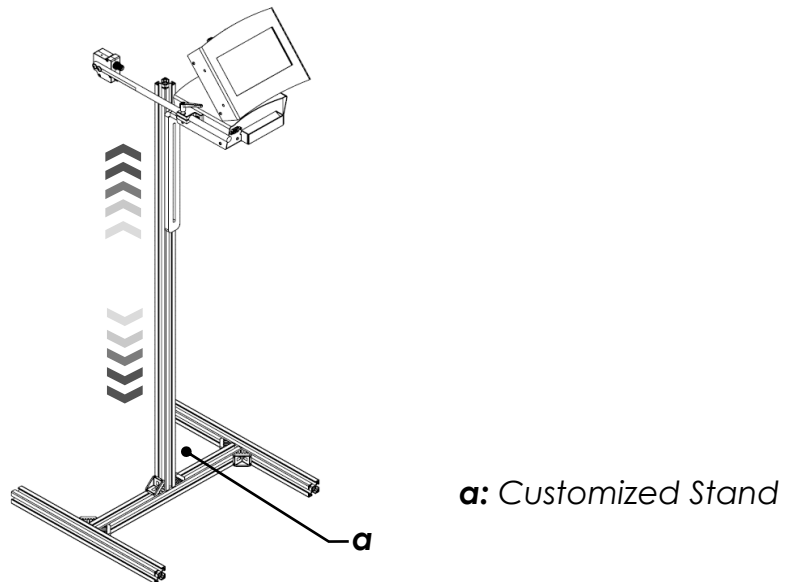

**a:** Customized Stand

Figure 9

## Rod

The print head is mounted on the ink system with the rod shown in Figure 10. Align the holes on the rod and print head and use shorter M5x0.8-Lever handle screw to fix the print head. Gently slide the Rod into rod mount and tighten the Longer Lever-Handle Screw. See Section “Adjusting the Slider Clamp” for more details.

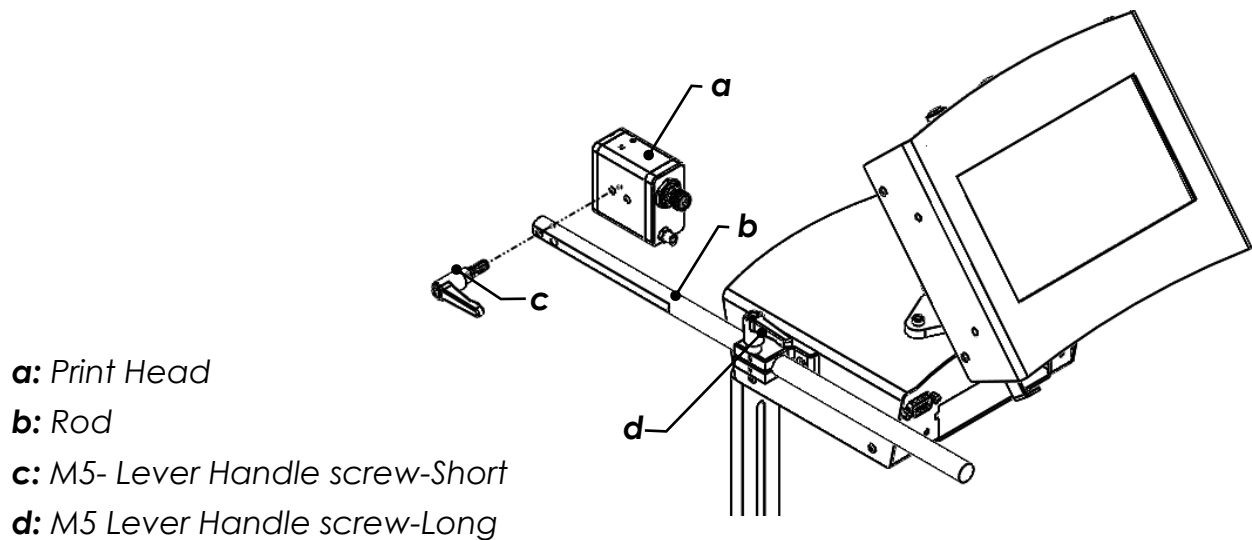

Figure 10

## Ink tube

*The printer head is pre-loaded with residual amount of ink which will be expelled during installation. Holding or placing an absorbent material between the printer head assembly and the conveyor is recommended at the time for set-up and mounting. Do not forget to remove it before testing and operating.*

- Fasten the Filter-Needle assembly into the nut devised on the ink system (see Figure 11).

**Notice:** This is a plastic part and can be damaged if over-forced or not properly aligned.



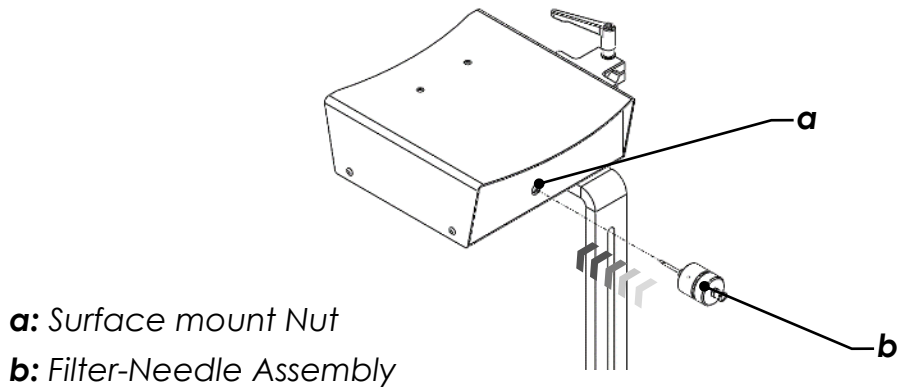

Figure 11

- Unscrew the plastic tube cap located on back side of the print-head (see Figure 11).

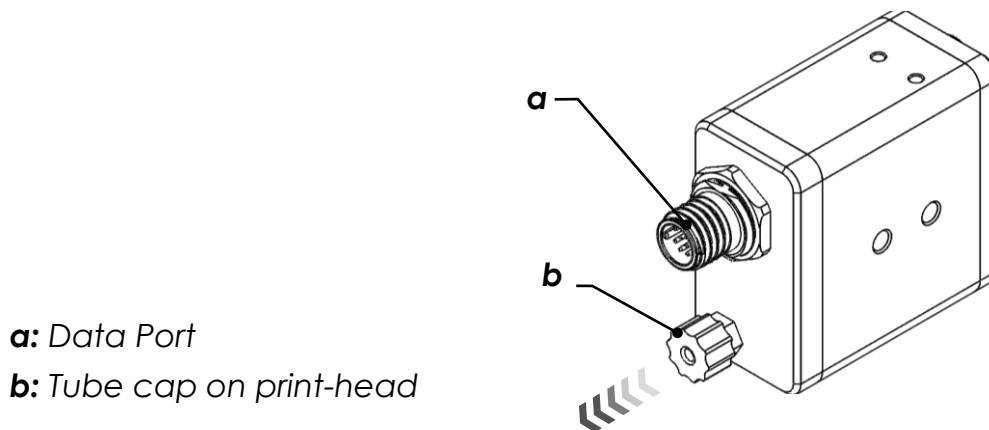
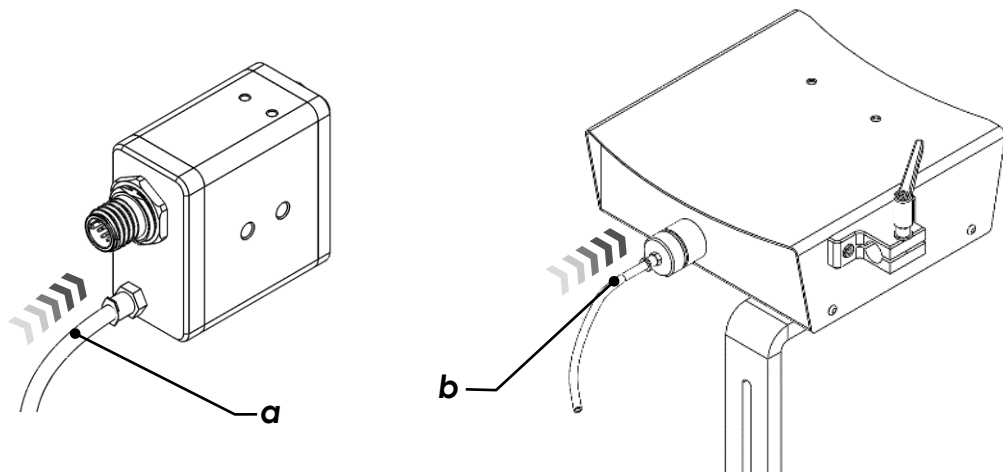

Figure 12

- Insert one end of the ink supply tube in the fitting located at the back of the printhead and press firmly into place (see Figure 13).
- Connect the other end of the ink supply tube to the fitting located on back of the ink system and press firmly in place.

**Notice1:** Retain the caps for potential re-use during disassembly for storage or transport.

**Notice2:** Ink tube can be routed properly after adjusting the print head and fixing it in the desired location (See Section **Adjusting the Slider Clamp**).



- a:** Ink tube inside printhead fitting
- b:** Ink tube inside Ink system fitting

Figure 13

## Controller

- Align the holes on the top of the ink supply unit and the controller pivot mount as shown and fix it using two M4 screws.
- Align the holes on the back of the controller with other two holes on the controller pivot mount and use two M4 screws to fix it in place (see Figure 14).

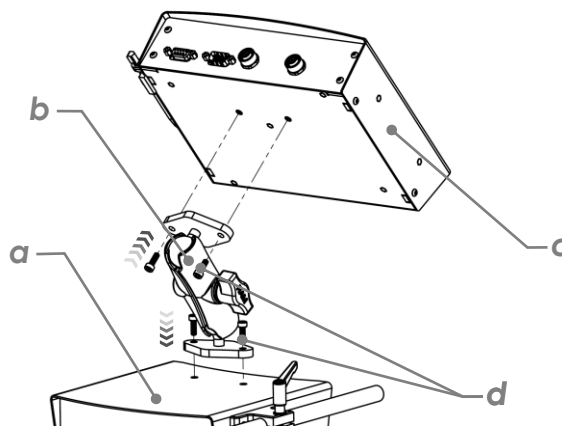

- a:** Ink system
- b:** Pivot Mount
- c:** Controller
- d:** M4 machine screws (x4pcs)

Figure 14

- While firmly holding the controller, turn the knob located on the pivot mount counter-clockwise to disengage clamping force.
- Adjust the positioning of the controller to the desired position for viewing and safe operation.
- Once the optimal position is determined, turn the knob on pivot mount clockwise to engage the clamp force and tighten in place. The controller should be rigid and not move during use (see Figure 15).

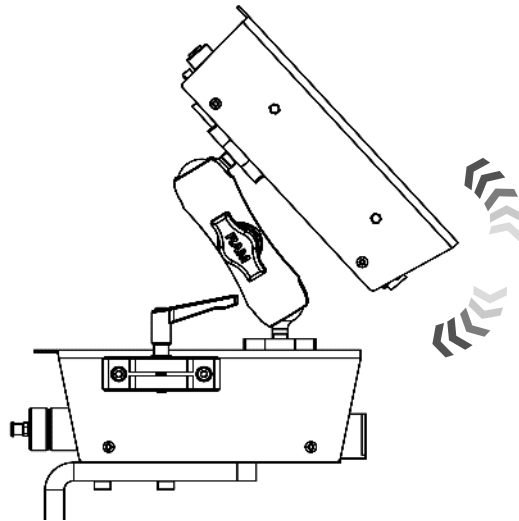

Figure 15

## Power Supply

- Insert the male end of the power adapter cable supplied at the back of printer (refer to Figure 16).
- Connect an applicable length power cord to the power adapter and plug into power source supply (single phase/120/240V AC 15 amp circuit). Avoid where possible the use of extension cords.

**Notice:** Due to different plug adaptors around the world and to avoid any misuse of connections, power cord is not provided and should be supplied locally.

- Toggle the two-position power switch to the “ON” position when printer operation is required.

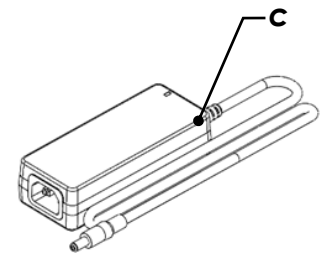
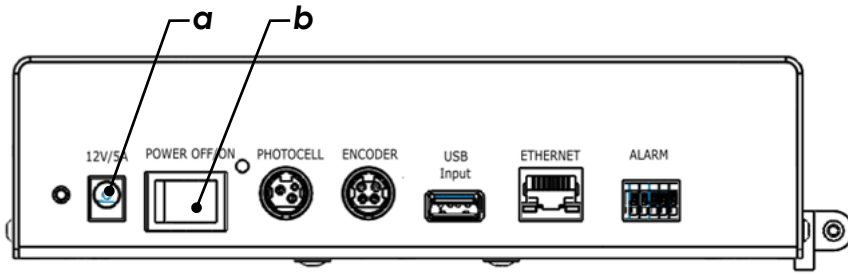

**a:** Power connection

**b:** On/Off button

**c:** Power adaptor

1. Fit the holding clip to the connector

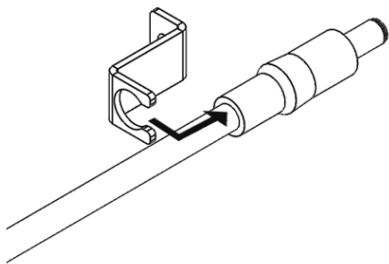

2. Plug the cable into the controller

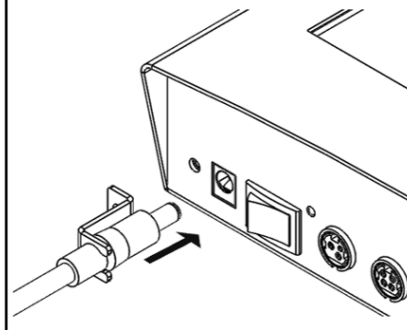

3. Fix the power cord with M3 screw

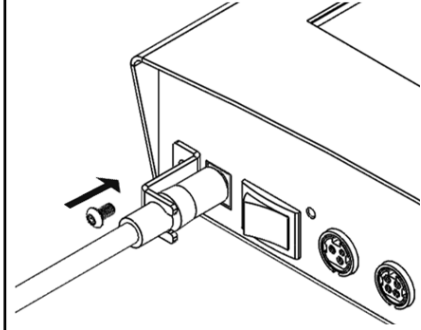

Figure 16

## Data Connections

**Notice:** DO NOT Connect/Disconnect the connectors when the power button is ON.

**Notice:** Power, data and sensor input cables must be inserted appropriately in their respective locations. Where possible, route cables away from moving objects and secure via tie-wraps.

### Photocell Sensor

For print trigger, a photocell sensor is included. Photocell sensor works as Light ON trigger. Please see Figure 17.

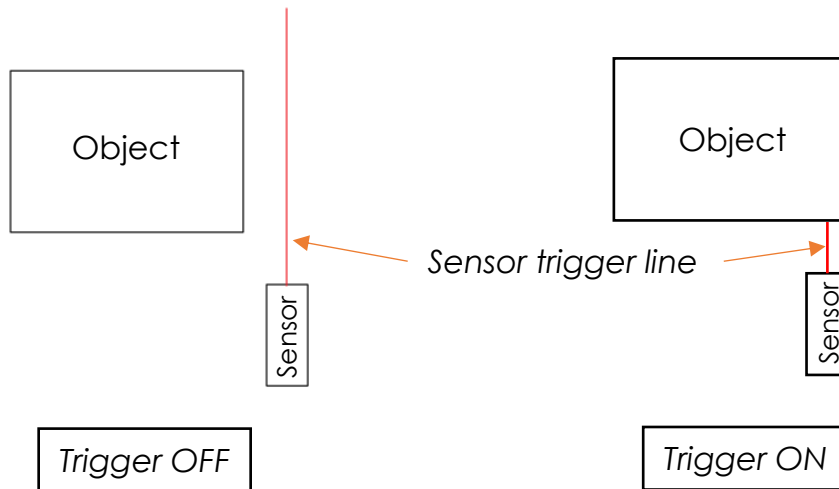

Figure 17

As shown in Figure 18, the printer system provides an NPN sensor signal input which triggers print command. It could be used with any 12 VDC NPN sensor.

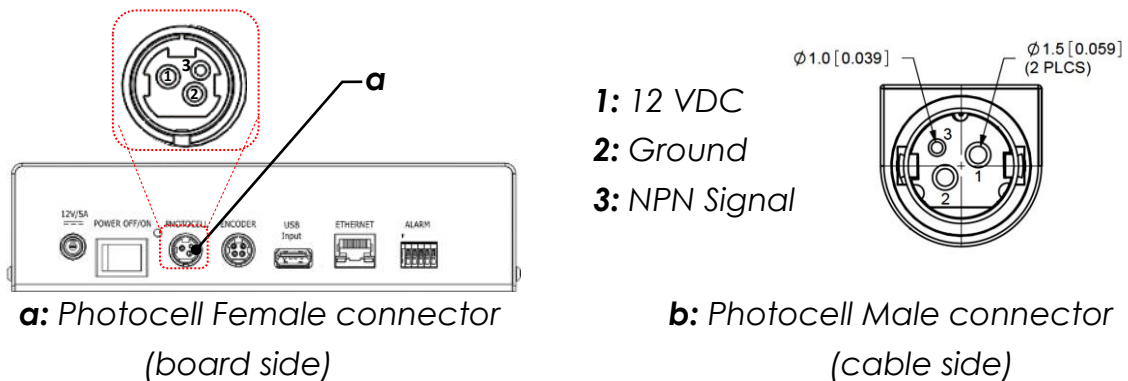

Figure 18

A Photocell sensor with proper 3-Pin connector as well as a photocell mount bracket is included for versatile mounting on conveyor system.

**Notice:** Photocell mount can be installed on the print head using M3 screw provided on devised threaded holes, or any other desired location based on print configuration. It is recommended to install it as close to the printhead as possible.

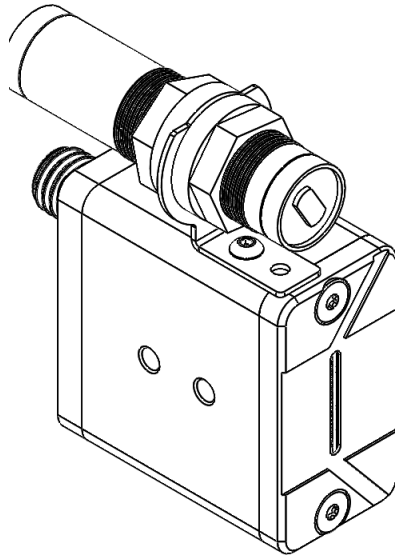

Figure 19

Slide the sensor through the sensor mount and re-secure by installing one locking nut from the top and the other from the bottom as shown on Figure 20. Finger tighten both locking nuts until there is no movement between the sensor and mount.

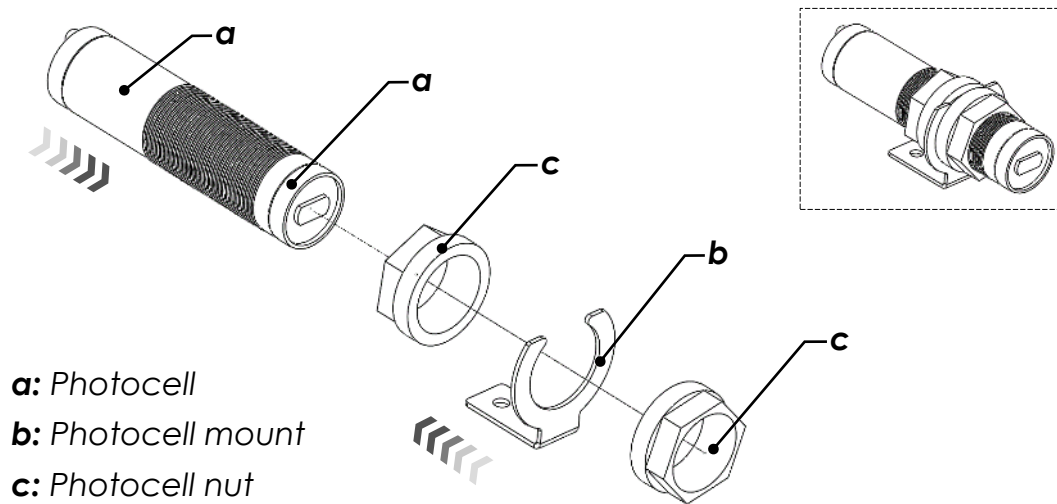
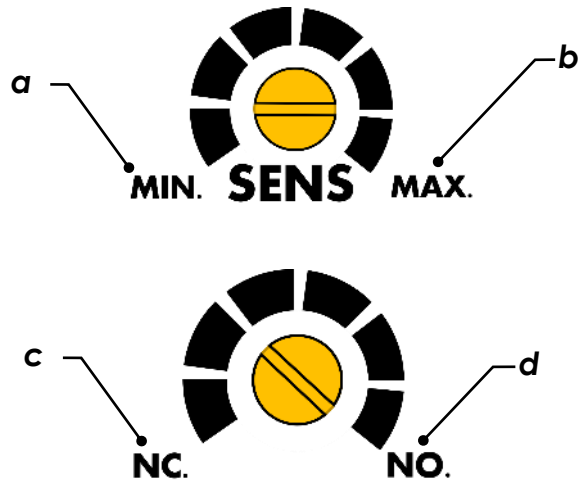

Figure 20

As shown in Figure 21, There are two settings on the photocell sensor body for adjusting sensing range (270° Potentiometer) and operating mode (2 positions).

Sensor is more sensitive to lighter colors (Highest: White) and less sensitive to darker colors (Lowest: Black). It also must be in Normally Open mode to trigger the print every time the printing substrate passes by.



- a:** Minimum Sensitivity (distance)
- b:** Maximum Sensitivity (distance)
- c:** Normally Closed Mode
- d:** Normally Open Mode

Figure 21

**Notice:** Sensor is preadjusted to Max sensitivity and Normally Open mode. Please do not touch the settings unless required otherwise.

### Shaft Encoder

Printer system is shaft encoder ready and provides a 12 VDC signal input (NPN configuration) on board which triggers print command (Figure 22). This function is available on demand. Consult your distributor for more details.

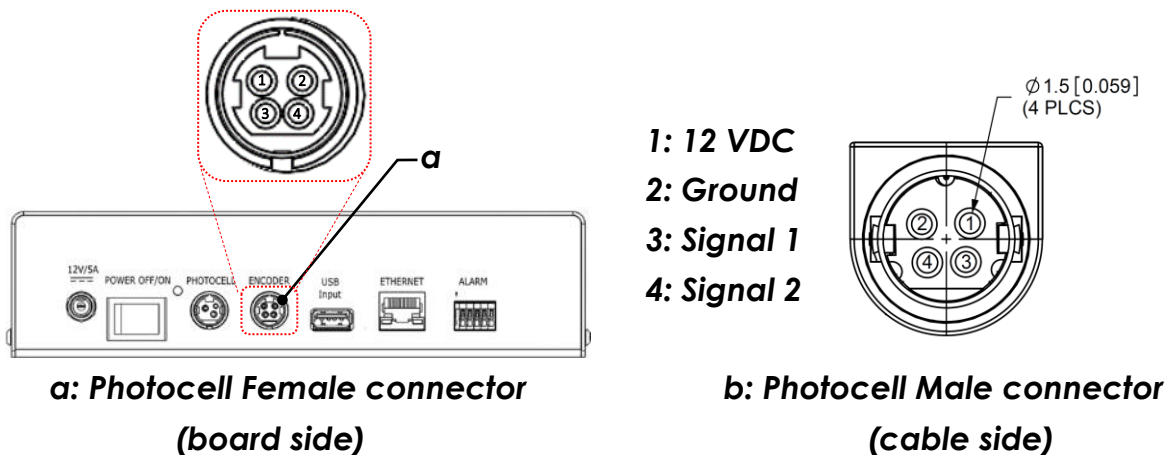

Figure 22

The print head resolution is **R=180 DPI**. For an encoder with **N** number of pulses per revolution, Wheel Diameter **D**, is calculated by equation below:

$$D = \frac{N}{\pi R} [in] \quad \text{or} \quad D = \frac{25.4N}{\pi R} [mm]$$

The units used in the shaft diameter calculation formula for **n=1** revolution is as shown below:

$$D[in] = \frac{N [pulse/rev] \times n[rev]}{\pi R[pulse/in]} \quad \text{or} \quad D[mm] = \frac{N [pulse/rev] \times 1[rev]}{\pi R[pulse/in]} \times \frac{25.4 [mm]}{1 [in]}$$

For example, the wheel diameter for a Shaft Encoder with **N=1800 pules per revolution** is:

$$D = \frac{1800 \times 1 \times 25.4}{180\pi} = 80.8mm (3.18")$$

## USB

USB port is used for data uploading on typical flash drives compatible with USB2.0 connections and should not be used for any other purposes.

**Notice:** Before turning ON the machine, insert the USB in the USB connector which is located on the side of the printer

**α: USB Port**

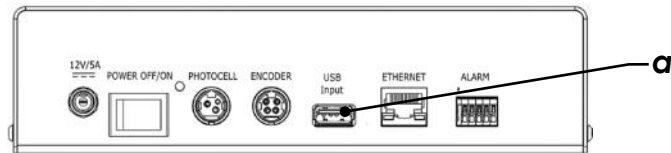

Figure 23

## Ethernet

Ethernet connection is capable of connecting print system to external controllers using IP based communication with PCs, PLCs, etc. Print system programming and message layout uploading/downloading is managed through this port.

**Notice:** For more information on print system configurations and Ethernet connection capabilities, please refer to "USER's MANUAL" accompanied with the device.

**α: Ethernet Port**

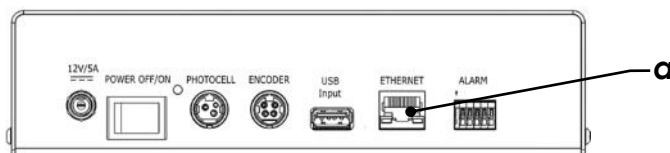

Figure 24



## External Alarm Terminal (Cartridge Ink System only)

An external beacon alarm can be connected to the alarm terminal if necessary. Pin 1 is the first terminal on the left. The pin out is indicated in Table 1.

**a: Alarm Terminal**

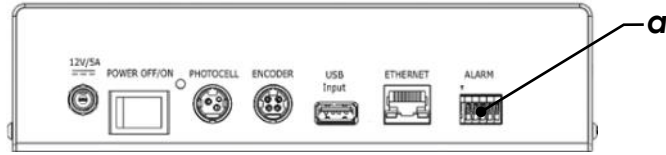

Figure 25

**Notice1:** This function is not available in H-Series.

**Notice2:** For Bulk ink system use the port on the ink system and avoid using this port.

Pin#	Color	Function
1	Green	Print ON
2	Yellow	Ink Low
3	Gray (GND)	-
4	Red	No Ink/Tag Lost
5	Reserved	-

Table 1. External Alarm Terminal Pin Out

## Ink Data

Controller communicates with ink system while printing and it would stop if this connection were lost.

**Notice:** Connect the cables provided accordingly before turning on the Printer.

**Notice:** DO NOT Connect/Disconnect the connectors when the power button is ON.

**Notice:** Power, data and sensor input cables must be inserted appropriately in their respective locations. Where possible, route cables away from moving objects and secure via tie-wraps.

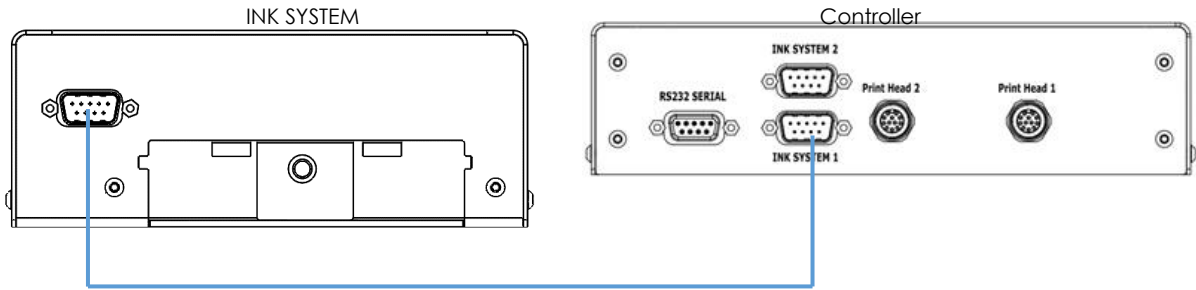
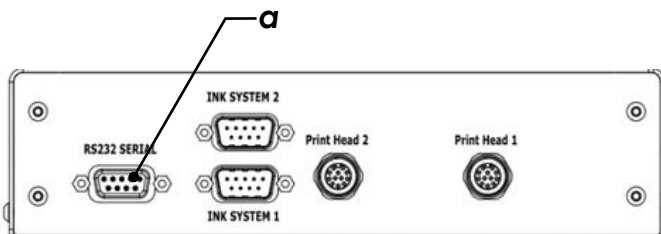

Figure 26

## Serial Port (RS-232)

RS-232 port, shown in Figure 27, is used for data communication through PLC/PC for external command/TEXT through compatible RS-232 cables and should not be used for any other purposes (for more information please refer to "USER's MANUAL" accompanied with the device).

**Notice:** Before turning ON the machine, insert the RS-232 connector which is located on the side of the printer.



**a:** Serial Port (RS-232)

Figure 27

## Print Head Ports

Print head drivers need to be connected to the ports on the Controller (shown in Figure 28) via provided cables.

**Notice:** Connect the cables provided accordingly before turning on the Printer.

- a:** Head1 (12 PIN Female Port)
- b:** Head2 (12 PIN Female Port)
- c:** Groove

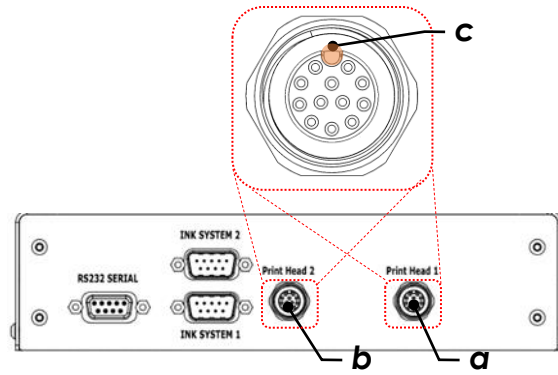

Figure 28

The ports on the controller are Female type and therefore must be connected to the Male Pin side of the cable. The plastic tongue on the cable connector must be aligned with the groove on the female connector and gently finger tighten the threaded part into the port. The arrow indicator on the connector shows the location of plastic tongue and must always be faced up.

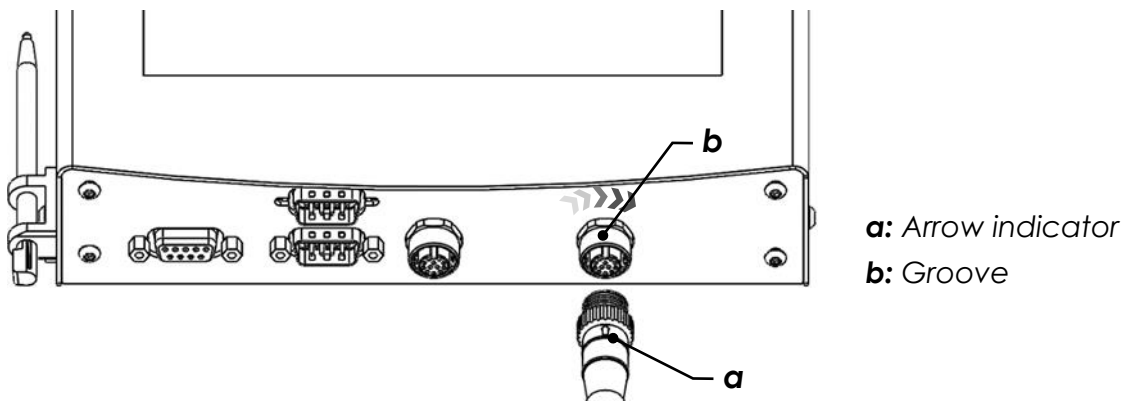

Figure 29

The other end of the cable is Round 12 Pin Female connector which also has an arrow indicator for the groove, must be aligned with the plastic tongue on the Print head port as shown in Figure 30.

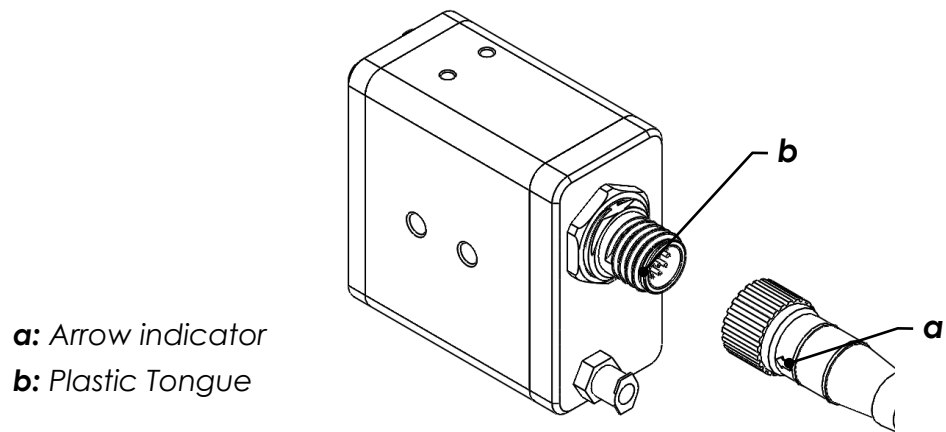

Figure 30

**Notice:** The threads on the connectors are meant to be finger-tightened and must never be over forced by wrench or mechanical tools.

# Start-up

## Adjusting

### Adjusting the Slider Clamp

- Loosen the lever handle screw to free the Rod mount (slider clamp) as shown in Figure 31.
- The Rod can be moved in and out once the lever handle screw is not fully tightened.
- Adjust clamp slide according to the distance between the printer head and printing surface (see next section “Adjusting the Printhead” for more information regarding printing position)

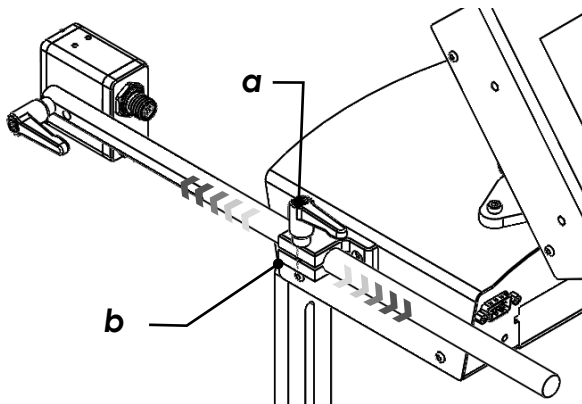

**a:** Lever Handle Screw-Long  
**b:** Slider clamp

Figure 31

### Adjusting the Printhead

**Notice:** Adjusting the Printhead is identical for the second head. The following pictures are shown only for one head. DO NOT run conveyor during the adjustment process.

- Place a printable sample on the stopped conveyor in the approximate location where printing is to take place.
- For some applications printing surface is neither vertical nor horizontal. If it is required to print in angle loosen the Shorter M5 lever handle screw to release the head. Bring it to desired position and tighten the lever screw on the printhead assembly.

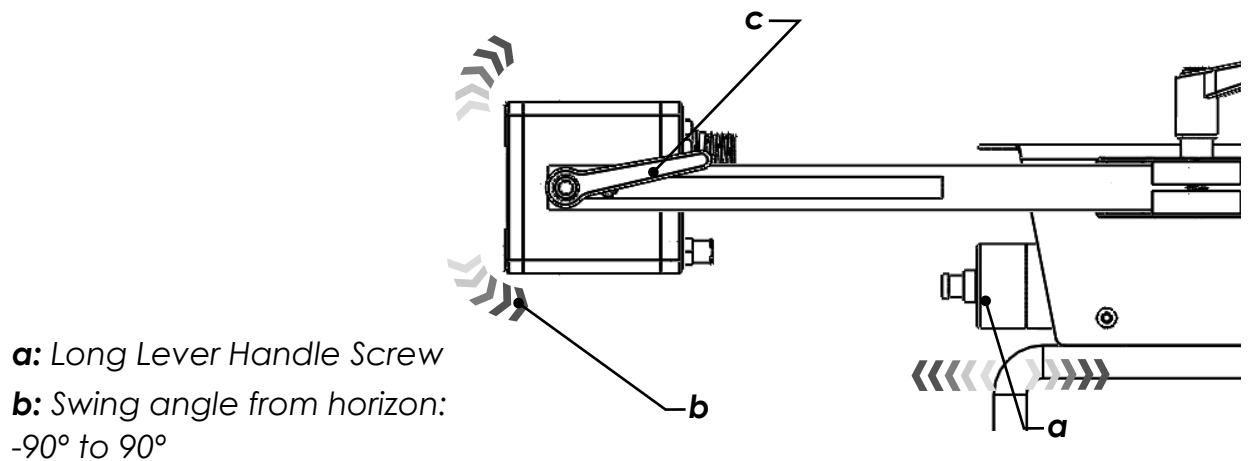
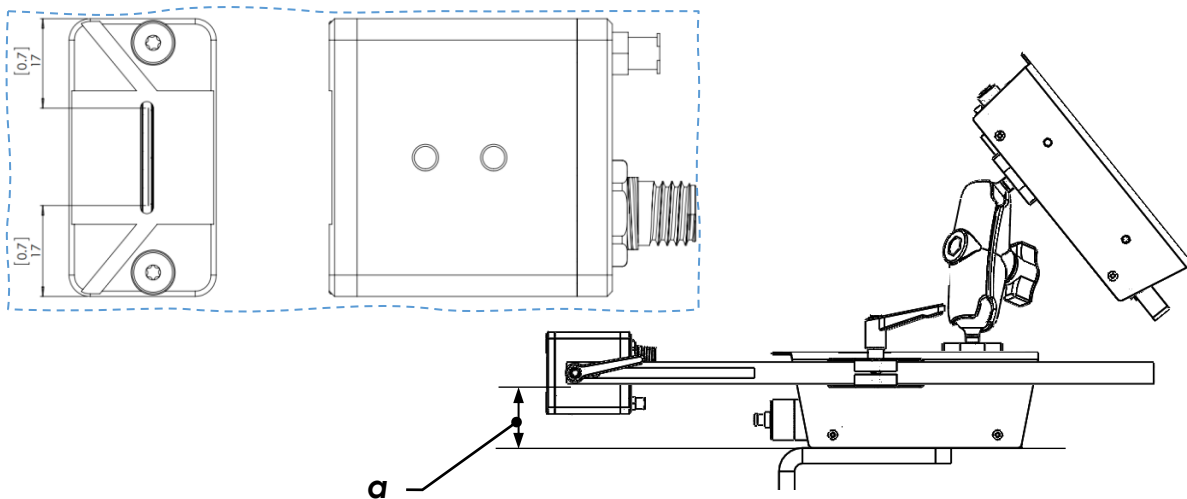

Figure 32

**Notice:** The ink supply system uses a gravity fed negative pressure to feed ink to the print nozzles. In order to maintain the optimal vacuum pressure (negative pressure) the print engine nozzle must be 40-50mm vertical distance away from the bottom of the ink supply system.



**a:** distance between lowest nozzle and bottom of the ink supply

Figure 33

The **operating distance** between the exposed print nozzles on the cartridge and the desired printable surface **is 1-10mm** (see Figure 34). This may vary depending on the printing speed and operating environment conditions (see Figure 34).

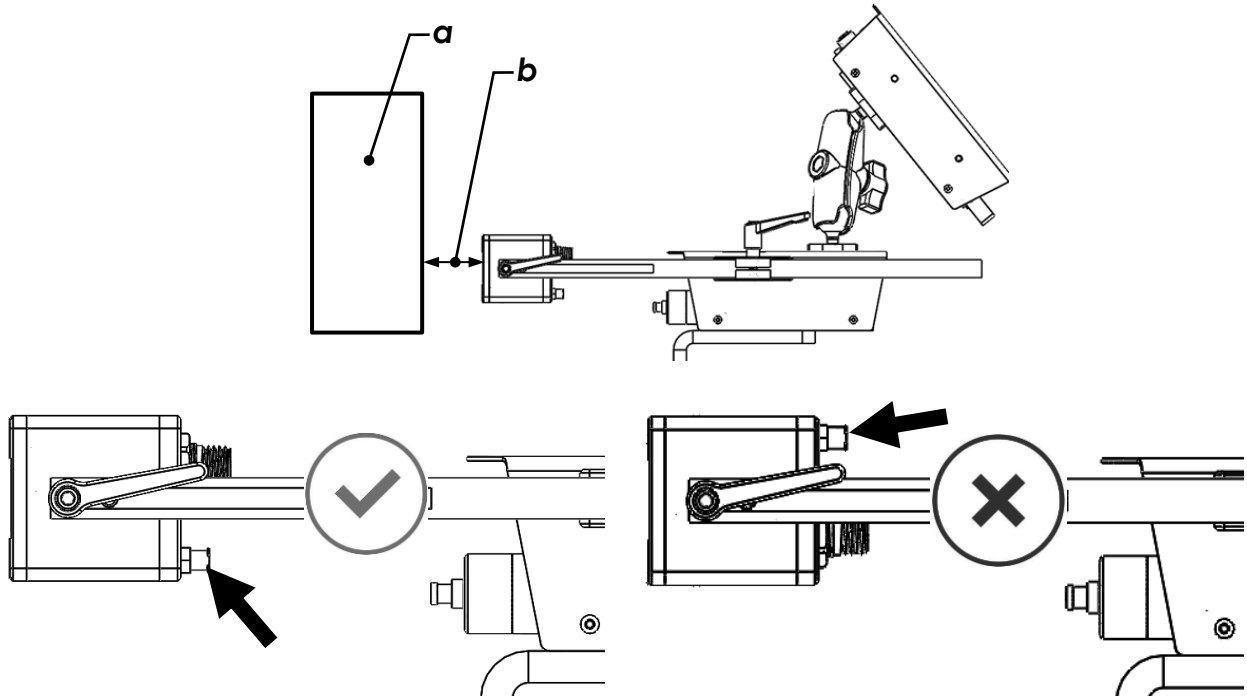

**a:** Substrate

**b:** distance between Printhead and substrate [1-10 mm]

Figure 34

**Notice:** Care must be taken to ensure that no part of the moving object comes in direct contact with the printer head assembly, clamping slider, ink supply tube or any cables or cords.

# Printer Head Positions

## Horizontal

**Notice:** Always make sure the printhead is under the slider arm, which assures printhead in the preferred level with device bottom side in horizontal direction.

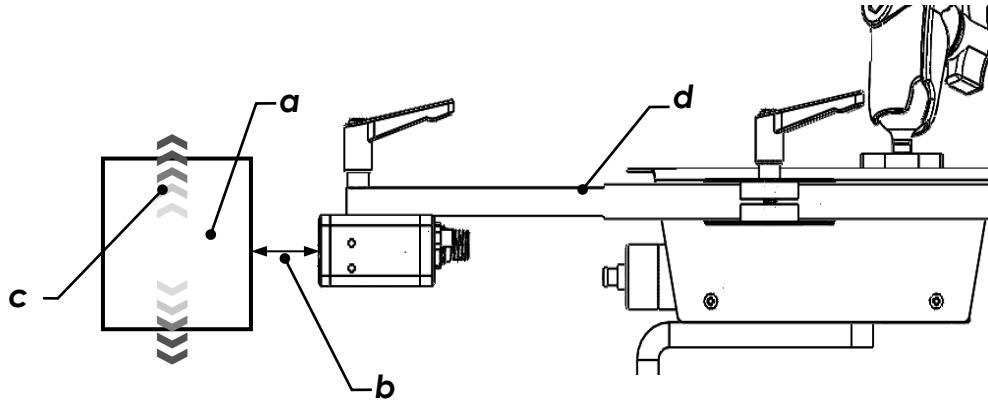

**a:** Substrate

**b:** distance: [1-10 mm]

**c:** Substrate direction of movement

**d:** Slider arm

Figure 35

## Skyscraper

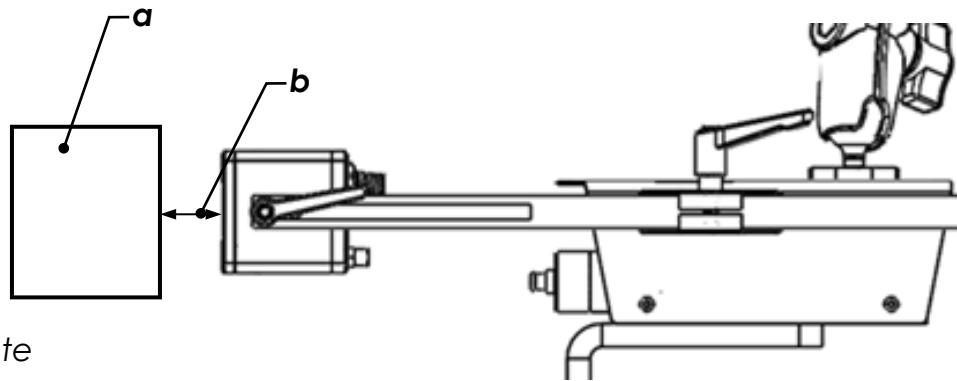

**a:** Substrate

**b:** distance: [1-10 mm]

Figure 36



## Down-shooter

**Notice:** In down-shooter position, remember to wipe printer head nozzles thoroughly after purge (See “Priming / Purging” on Page 25).

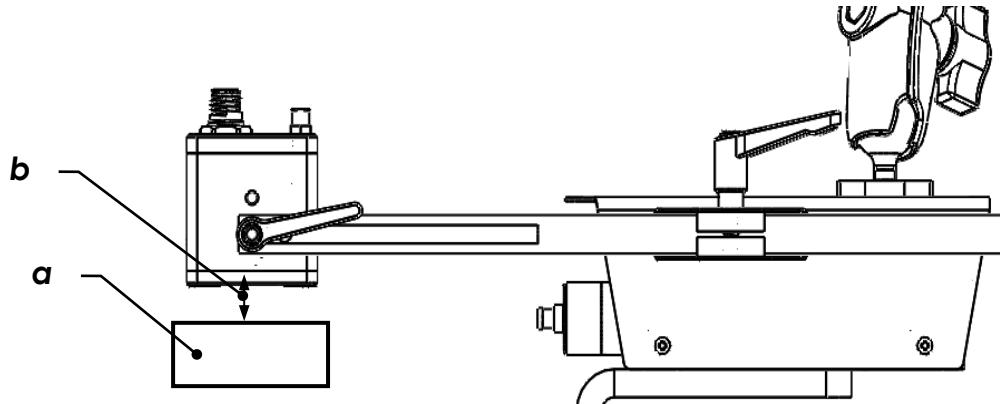

**a:** Substrate

**b:** distance: [1-10 mm]

Figure 37

## Inserting Ink cartridge

RN MARK ink cartridges are precisely filled, and quality tested before delivery to customers. Hence, they have optimum results and print quality when used in RN MARK printing systems.

**Notice:** For best results, always use RN MARK premium ink cartridges.

- Insert the ink cartridge into the cartridge slot located at the front of the ink supply system.
- Ease the cartridge into the unit until it is within the ink system and tightly gripped (see Figure 38).

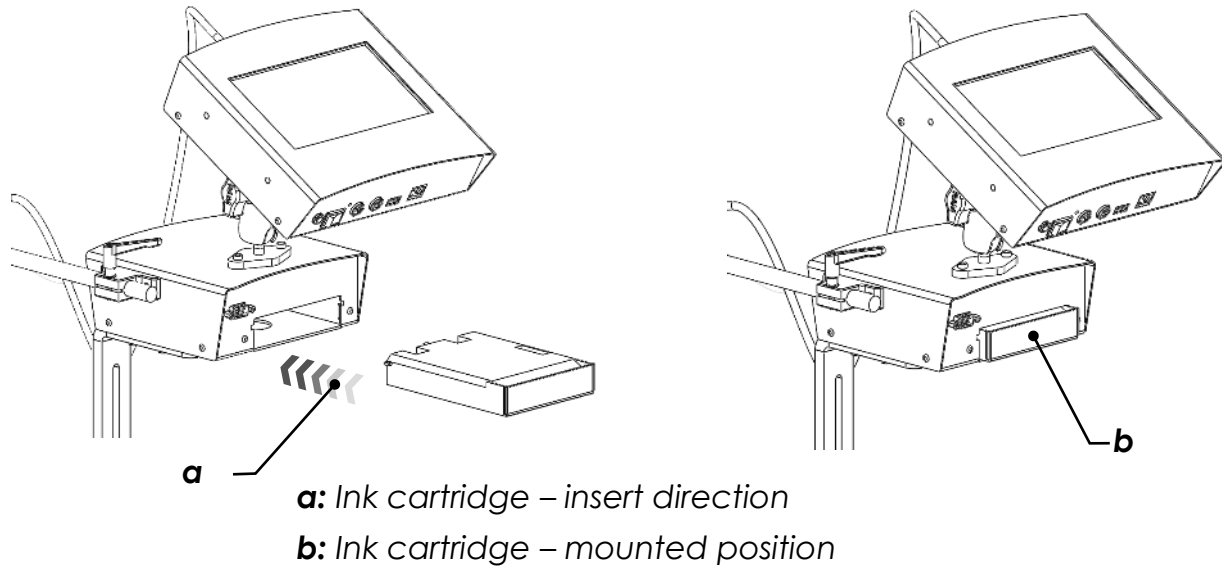

Figure 38

## Priming / Purging

The ink system must be primed and purged before every first print. It is recommended that an absorbent material be held or placed below the printer head during purging, as ink will be expelled during the purging and test printing.

- Push purge button located on the bottom of the ink cartridge through the round opening located on the underside of the ink supply unit until ink flows from the print head nozzles (see Figure 39).
- Continue to push the ink button until ink flows from printhead nozzles and no air or bubbles are visible inside the ink supply tube or the printhead.

**Notice:** The ink will gradually bleed from bottom to top of the nozzles.

- Blot or dab the print nozzle guard with an absorbent material to remove any expelled ink.

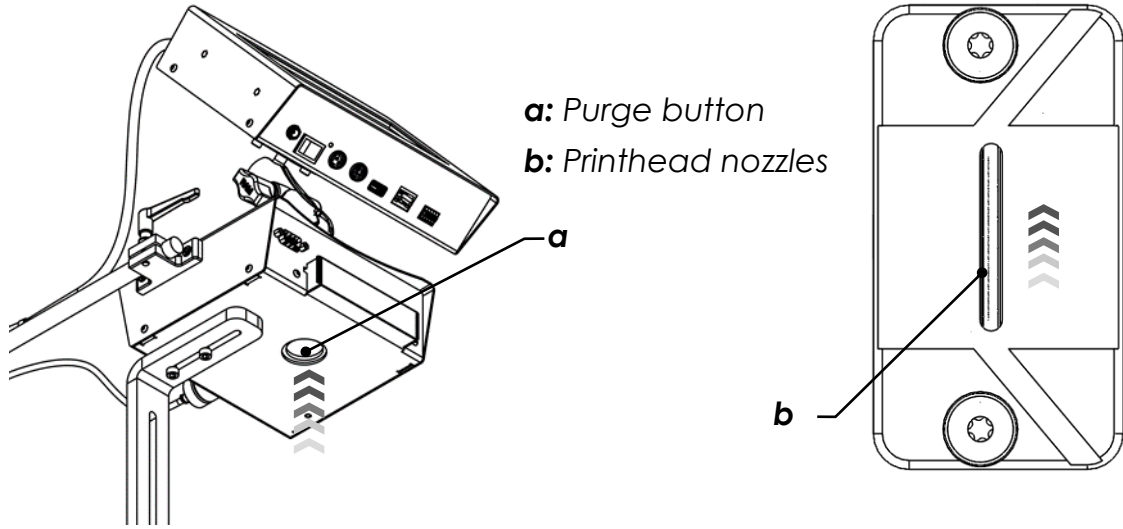

Figure 39

# Maintenance and Services

The printer head may require cleaning and maintenance due to environmental or product debris such as dust, hair, fibers etc. Care must be taken during cleaning to ensure the exposed print nozzles are not damaged.

**Notice:** Use only *RN MARK* Spray cleaner for printhead maintenance.

## Cleaning the Printer Head

- Loosen the printer head clamping screw and adjust to expose the print nozzle cover (if required).
- Retighten clamping lever.
- Hold or place an absorbent material directly below the printer head.
- Sparingly spray the print nozzles and print nozzle cover with specially formulated **RN MARK Cleaner**.
- DO NOT RUB the print nozzle cover. If necessary, blot excess cleaning solution with an absorbent material.
- Loosen clamping screw, return the printer head to its original print position and re-tighten firmly.
- Test print sample before resuming production printing.

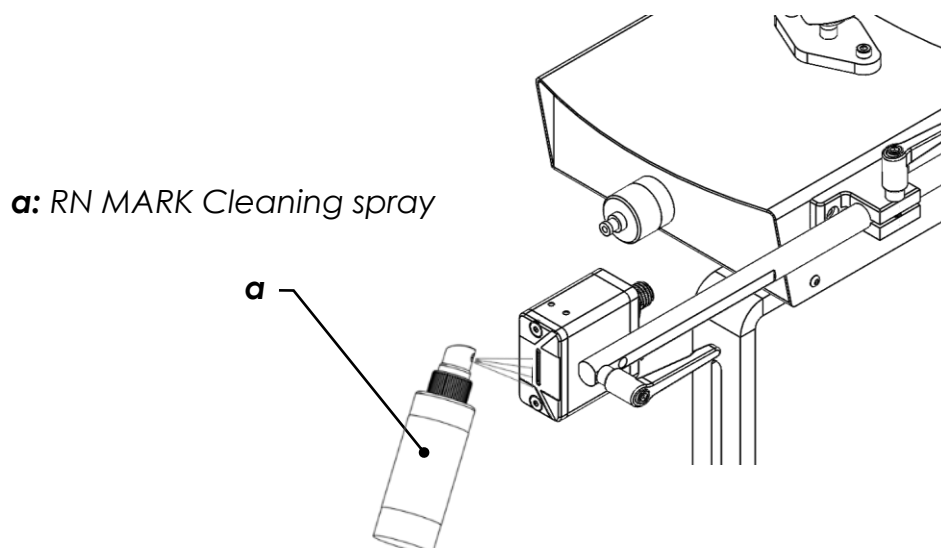

Figure 40

## Flushing the Print Head

There are circumstances in which print head is required to be flushed. Please follow steps below to have a worry free and safe process (see Figure 41).

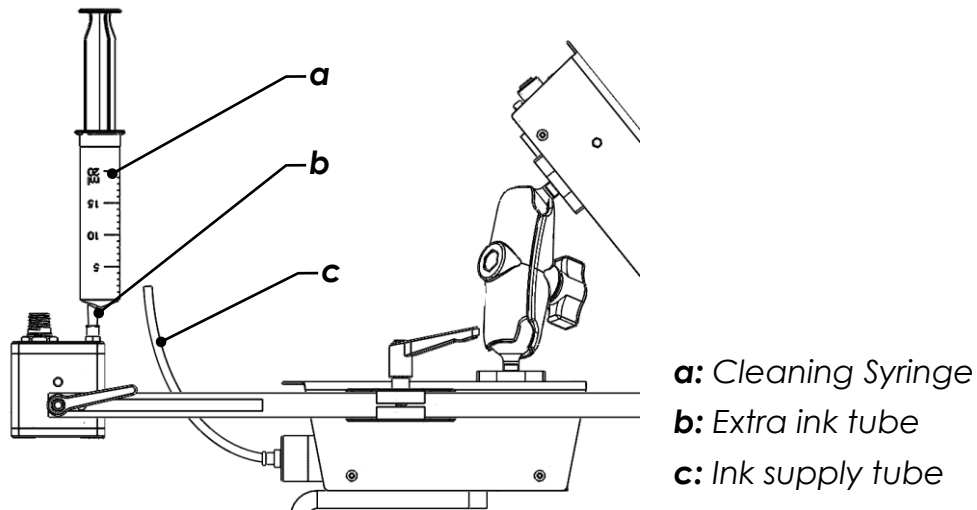

Figure 41

**Notice:** During process, the printing system must be unplugged and turned off.

1. Adjust the printer head until the connector side is horizontal/face-up.
2. Unplug the ink tube from print head and keep the tube level above the ink system to drain the remaining ink into the cartridge.
3. Remove the ink cartridge for storage or disposal.
4. Spray some cleaner on the nozzle plate to dissolve the dry ink residues on the external surface of nozzles.

**Notice:** Always hold a container under print head to avoid ink spillage in the working environment.

5. Fill the syringe with air and plug it into the ink inlet and push the piston to discharge the residual ink inside the print head as much as possible (Repeat Two times).
6. Disconnect the syringe, draw a small amount (<20cc) of RN MARK Cleaner into it and plug it back to print head.
7. Discharge cleaner solution to wash the dye/pigment and unclog the nozzles.
8. Repeat Steps 5-7 if required.

9. Check the tube for dried ink residues and replace it with new one if necessary.
10. Plug the ink supply tube back to the print head and adjust the print head to printing position.
11. Insert the cartridge and purge until ink bleeding from all nozzles with no bubbles
12. Spray cleaner solution on the nozzles and dab the excess ink/cleaner.
13. Turn on print system and test for print quality.

**Notice:** If you are using a cleaner cartridge, follow the instruction to Step 4, insert the cleaner cartridge, and purge until you see clear solution dripping from ink tube. Plug it to the print head and purge to discharge the remaining ink. Purge 2-3 seconds more after clear solution starts to bleed from all nozzles. Take the cleaner cartridge off and follow the instructions from Step 10 forwards.

**Notice:** Never leave the print head without ink and possibly use it after flushing. If storage is required

**Notice:** If print quality is not satisfying, contact RN Mark Technical support team for more help.

## Changing the printing ink color

There are circumstances which leads to change of ink color for printing.

If so:

- Flush the print head as instructed in previous section.
- Replace the ink supply tube with a brand new one and make sure it is fixed in position.
- Insert new cartridge with desired color.
- Purge repeatedly until the ink with new color until bleeding from all nozzles with no bubbles.
- Spray cleaner solution on the nozzles and dab the excess ink/cleaner.
- Turn on print system and test for print quality.

**Notice:** If print quality is not satisfying, try repeating purging and cleaning printhead until desirable results take place.

**Notice:** Please make sure not to mismatch solvent based and oil based ink as these inks are not compatible

## Storage Ink (Maintenance Ink)

**Notice:** The storage Ink A.K.A Maintenance ink must be purchased separately.

If the solvent-based printer is supposed to be on stall for more than 10 days, printing ink should be replaced by maintenance ink as described below:

- Flush the print head as instructed in previous section.
- Flush the ink tube and reconnect it to print head.
- Insert the storage Ink cartridge and purge until storage ink (RED) bleed from all the nozzles.
- Try to print some sample messages with Maintenance Ink.
- Spray some cleaner solution on the nozzles. Fold a lint free paper towel to size of 5"x5" or 13x13 cm<sup>2</sup>. Spray some cleaner on it.

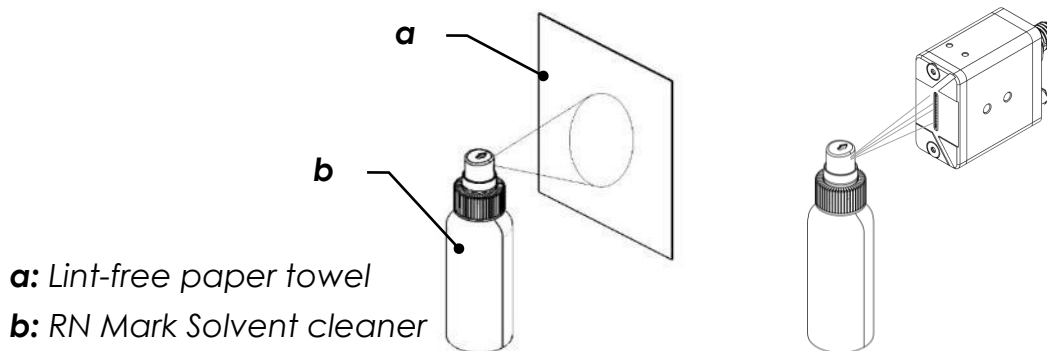

Figure 42

- Fold the sides in a way that it wraps around head and use a stretch wrap to seal the print head air tight

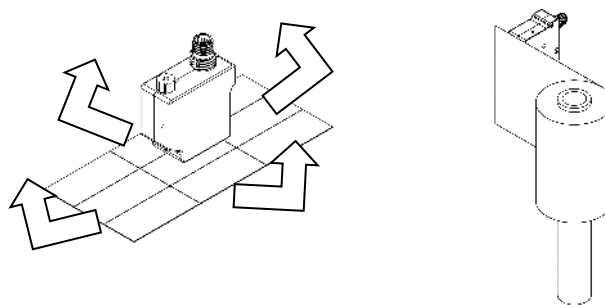

Figure 43

**Note:** Please note that this step is particularly important to keep the nozzles wet by minimizing ink evaporation to prevent clogging of the nozzles.

## Installation and Technical Support

Telephone and Whatsapp technical support is available in Canada and the U.S.  
Monday through Friday 9:00am to 5:00pm EST.

Toll-Free: 1 866 551 9406

Sales: 1 905 597 4977

Sales: 1 905 597 4978

Tech Sup: 1 905 597 9406

Tech Sup: 1 905 597 9406 (Whatsapp Available)

Questions and comments can also be sent to: [ts@rnmark.com](mailto:ts@rnmark.com)

[WWW.RNMARK.COM](http://WWW.RNMARK.COM)