

# RNJet 72/140 XL

Installation manual

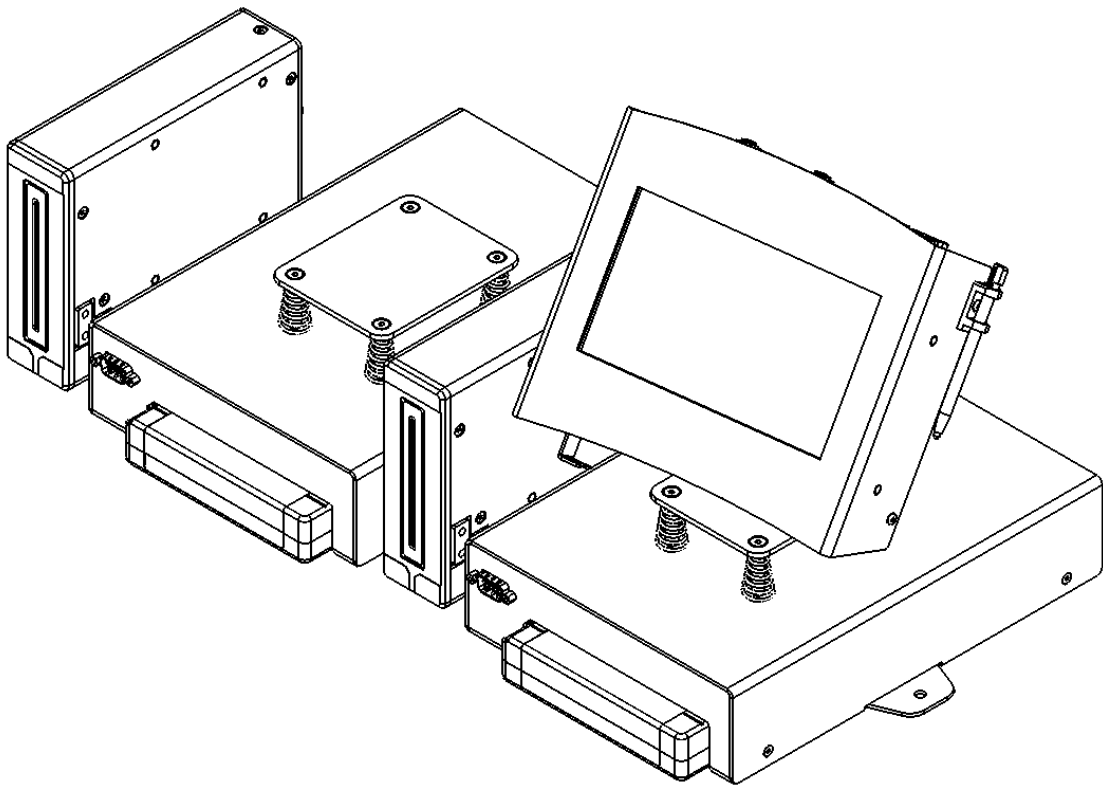





# **RNJet 72/140 XL**

## **Industrial Hi-Resolution Inkjet Printing System**

### **Installation Manual**

Revision 01 11/25/2024

All rights reserved. All trademarks and brand names are the property of their respective owners.

RN MARK INC.

25-16 SIMS CRES. RICHMOND HILL, ON  
L4B 2P1

TEL: +1(905) 597-4977; TF: +1(866) 551-9406; Whatsapp: +1(647) 242-8969

[www.rnmark.com](http://www.rnmark.com)

# Table of Contents

Notices & Cautions .....	1
Legal Disclaimer .....	1
Safety.....	1
Handling and care .....	1
Ink.....	2
Introduction .....	3
What's in the box.....	3
System specifications .....	4
Operating Temperature:.....	4
Accessories and Consumables.....	6
Ink cartridges and cleaners .....	7
Installation.....	8
Overview of Full System .....	8
Printhead.....	10
Ink System.....	11
L-Shape + Rod Mounts.....	12
Ink tube.....	13
Controller.....	15
Power Supply .....	16
Data Connections.....	17
Photocell Sensor.....	17
Shaft Encoder.....	19
USB.....	20
Ethernet.....	20
External Alarm Terminal (Cartridge Ink System only) .....	21
Ink Data .....	21
Serial Port (RS-232) .....	22
Print Head Ports.....	22
Start-up.....	24

Adjusting.....	24
Adjusting the Printhead.....	24
Other Printer Head Positions.....	26
Horizontal.....	26
Downward.....	26
Priming / Purging.....	28
Maintenance and Services.....	29
Cleaning the Printer Head.....	29
Flushing the Print Head.....	30
Changing the printing ink color.....	31
Storage Ink (Maintenance Ink).....	32
Installation and Technical Support.....	33

# Notices & Cautions

## Legal Disclaimer

Accessories could be different to this document without notification due to part shortage or design improvement.

## Safety

- During handling, installation, maintenance and operating procedures for the printing system, always follow safety regulations by wearing safety glasses, gloves and protective clothing.
- Keep all print system components and fluids away from open flames and excessive heat.
- In case of fluid eye contact, flush immediately with water and receive appropriate medical attention.
- The power source used for print system should comply with all safety regulations and codes required for safe plugging.
- Power, data and sensor input cables must be inserted appropriately in their respective locations. Where possible, route cables away from moving objects and secure via tie-wraps.

## Handling and care

The printhead engine is encased and the print nozzles are exposed through the nozzle guard. Extra precautions should be taken when handling the printer head during installation, operation and maintenance. Never use abrasive materials on or near the exposed print nozzles.

**Notice:** *Do not allow objects to be in direct contact with the print head's nozzles.*

## Ink

Inks come in different solutions, varieties, and codes (e.g. Oil-based, Solvent Based, UV, etc.), make sure to use identical ink for each printer system and avoid exchange of ink with other varieties.

**Notice:** *For best results, always use RN MARK premium inks.*



# Introduction

## What's in the box

Following are all the components that are included inside the RNJet 72 and 140 packages (see Figure 1). In cases that RNJet 140 require more components; quantities are shown inside the [].

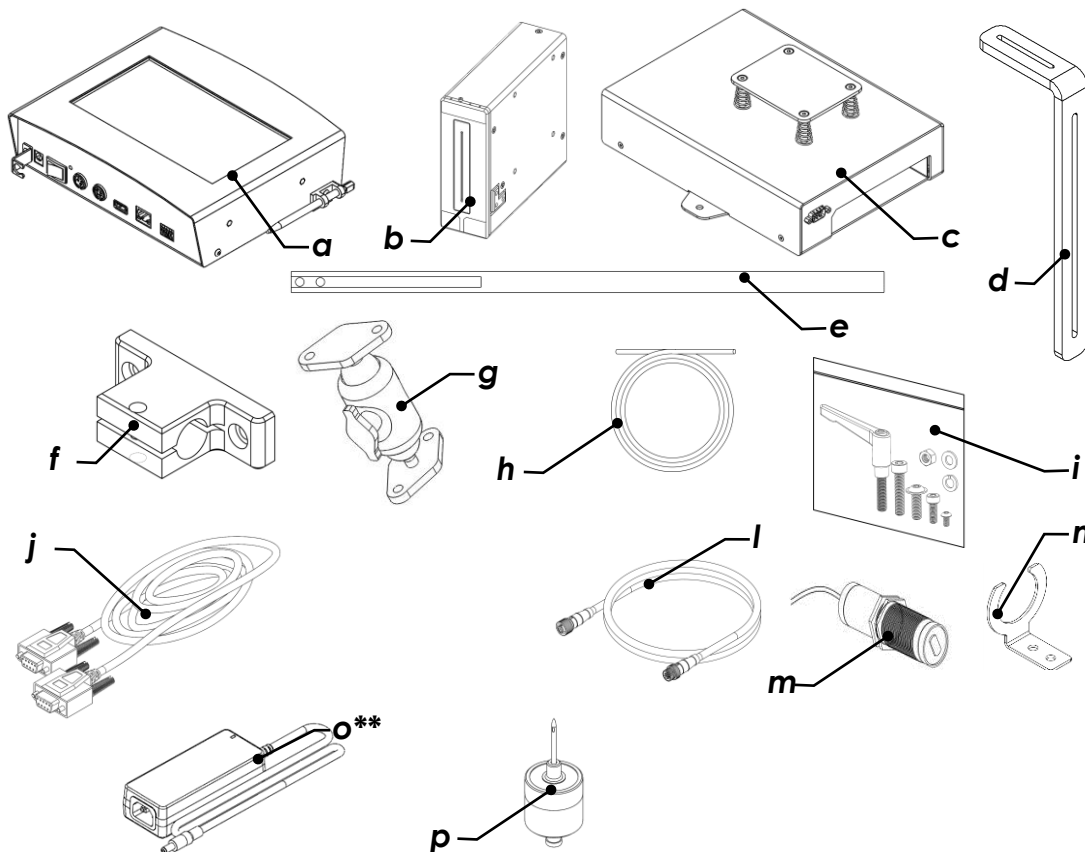

- a:** Controller x 1pc
- b:** Print Head x 1pc [2pcs]
- c:** XL Ink System x 1pc [2pcs]
- d:** L-shape Mount x 1pc [2pcs]
- e:** Rod x1pc [2pcs]
- f:** Rod Mount x 1pc [2pcs]
- g:** Controller Pivot Mount x 1pc
- h:** Ink Tube x 1pc [2pcs]
- i:** Screw Pack x 1set

- j:** Ink Data Cable x 1pc
- k:** Data Cable x 1pc [2pcs]
- l:** Photocell (Sensor) x 1pc
- m:** Photocell mount x 1pc
- n:** Power adaptor x 1pc\*\*
- o:** Filter-Needle Assembly x 1pc

\* Only for RNJet 140.

\*\* Due to different power plug standards worldwide, we do not supply the power cord.

Figure 1

# System specifications

## General

**Operating Temperature:** 0-45 °C

**\*Speed:** up to 1000 mm/s (40 in/sec)

**\*Resolution:** 180 pixels per inch

**Print swathe:** 72 mm (2.83") print height [up to 144mm (5.66"), conditions apply]

**I/O power:** (100-240 V 50/60 Hz 5.0A) / (12 V 60W)

**I/O data:** Ethernet, NPN Sensor input, integrated 7" Touch LCD input, Speed encoder control (shaft encoder)

**Cartridge:** Clean & Sealed ink cartridge

20 million characters per cartridge (based on 85 dots/character)

## Ink-Type Compatibility:

Oil-based inks for porous materials

Solvent-based for non-porous materials (CFIA Approved fast dry inks) and Solvent-based for porous materials.

UV ink Compatible

## Software:

Advanced layout design in RN Soft Windows-based OS (PC)

User-friendly layout design in RN Soft Linux-based OS (Touch LCD)

Dynamic Data Generation

Supports all general graphic input file types & True Type Fonts

## Supported Barcode Types:

1-D: All major 1-D barcode formats such as:

Codabar, Code, EAN, MSI, RSS, UPC, T F, GS1databar, etc.

2-D: QR-Code, ECC200 (Datamatrix), PDF417/macro, Aztec, etc.

## Standards & Certificates:

CE, FCC, CSA, ICES, Lead-free & RoHS compliant

\* These are the default values, refer to user manual for more information if higher speed is required.

**Dimension (in mm [inch]):**

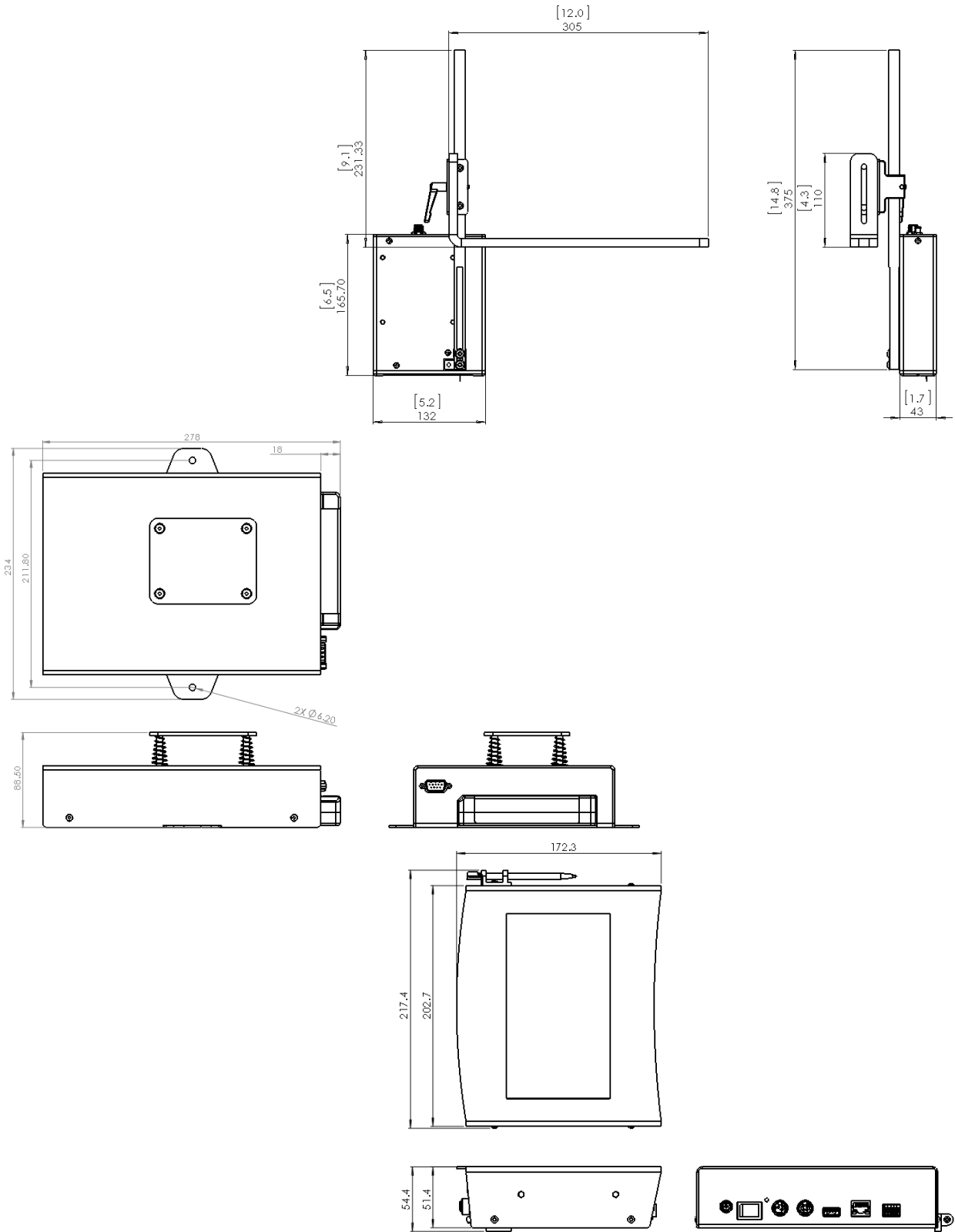

Figure 2

## Accessories and Consumables

Below are optional and essential items your device should have to operate or keep up with the maintenance schedule. (See Figure 3)

You could find more information on accessories and consumables on our website at [www.rnmark.com](http://www.rnmark.com)

**Notice:** Items below are not included in this package and should be ordered separately.

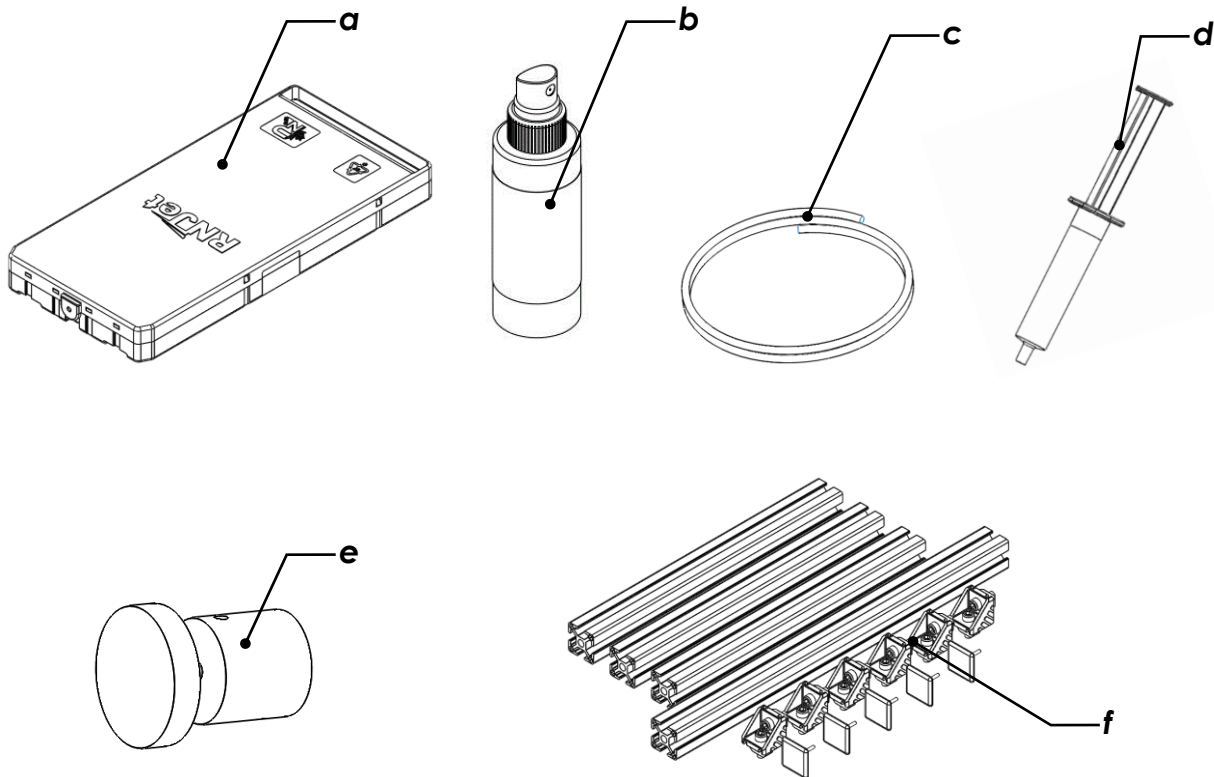

**a:** Ink cartridge

**b:** Cleaner Spray

**e:** Shaft Encoder

**c:** Extra ink tube

**d:** Cleaner syringe

**f:** Extrusions Mounting Set

Figure 3

## Ink cartridges and cleaners

**Notice:** For best results, always use RN MARK premium ink cartridges.

Please refer to list below for purchasing RN MARK premium ink cartridges:

### Solvent-Based Consumables:

Name	Description	Part Number
BSF BLACK-C	Black Solvent-Based Fast Dry Ink Cartridge	100-1609-101
BSF BLACK-E	Black Solvent-Based Slow Dry Ink Cartridge	100-1618-101
BSF BLACK-P	Black Solvent-Based Ink for Porous Material	100-1613-101
BSF RED-P	Red Solvent-Based Ink for Porous Material	100-1613-103
BSF-WHITE	White Solvent-Based Ink Cartridge	100-1602-104
BSF-YELLOW	Yellow Solvent-Based Ink Cartridge	100-1602-105
SC-110	Solvent-Based Cartridge Cleaner	100-1605-108
SC-120	Solvent-Based Spray Cleaner	100-1505-208
MS110-RED	Storage Ink Cartridge	100-1607-103

### Oil-Based Consumables:

Name	Description	Part Number
OIL-BLACK	Black Oil-Based Ink Cartridge	100-1604-101
OC-110	Oil-Based Cartridge Cleaner	100-1606-108
OC-120	Oil-Based Spray Cleaner solution	100-1506-208

For more information, please go to [www.rnmark.com](http://www.rnmark.com)

**Notice:** make sure to use identical ink bases for each printer system and avoid exchange of ink with other varieties. (ex. if you are using solvent-base ink never change to oil-based ink and vice versa)

# Installation

## Overview of Full System

### FOR DOWNWARD PRINTING

The below pictures illustrate the basic installation method of the full system. Please have these considerations in mind when applying to your application.

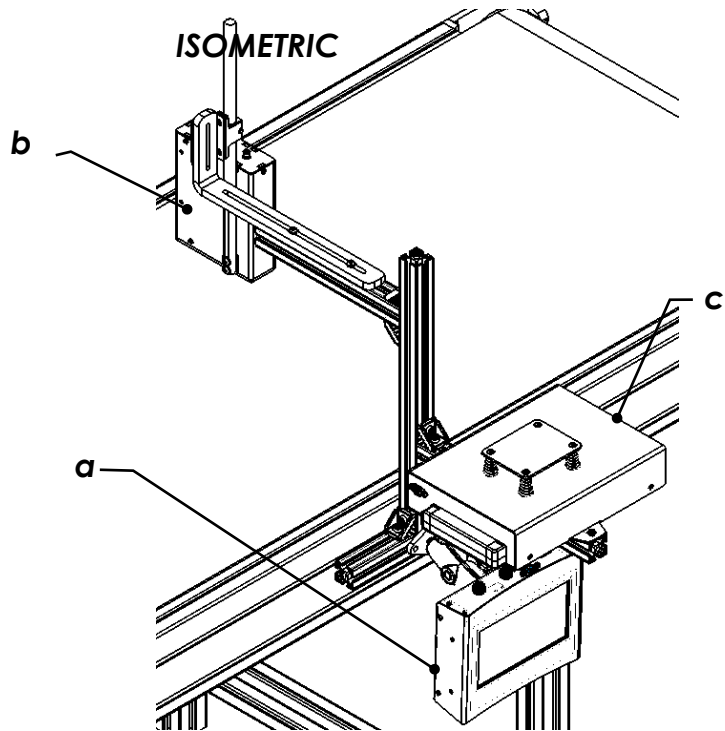

**a:** Controller

**b:** Print Head

**c:** Ink System

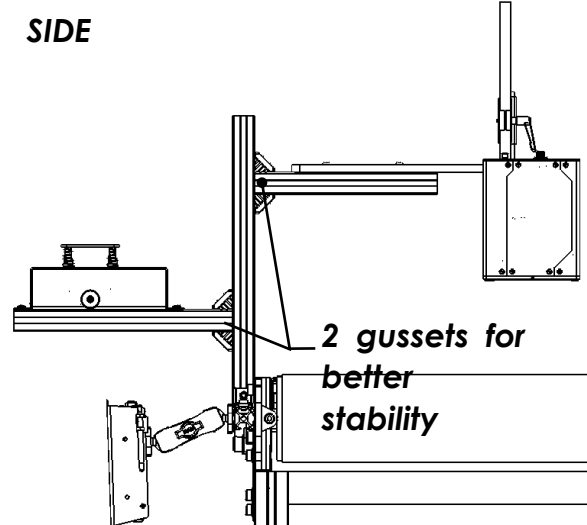
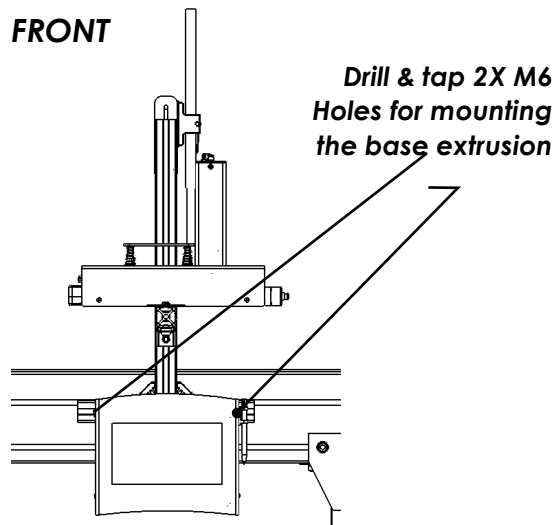

## FOR FORWARD PRINTING

The below pictures illustrate the basic installation method of the full system. Please have these considerations in mind when applying to your application.

- a:** Controller
- b:** Print Head
- c:** Ink System

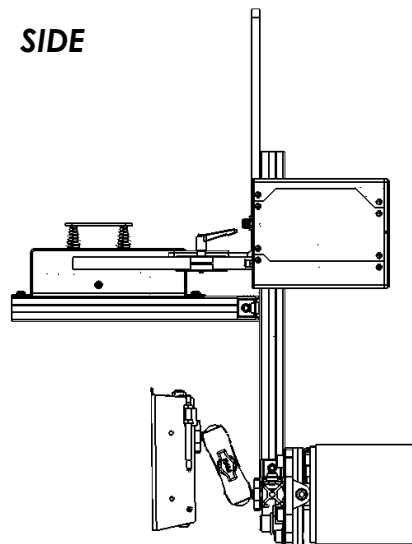
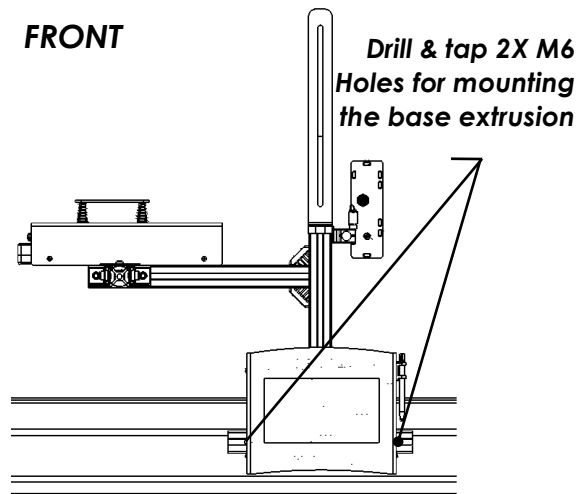
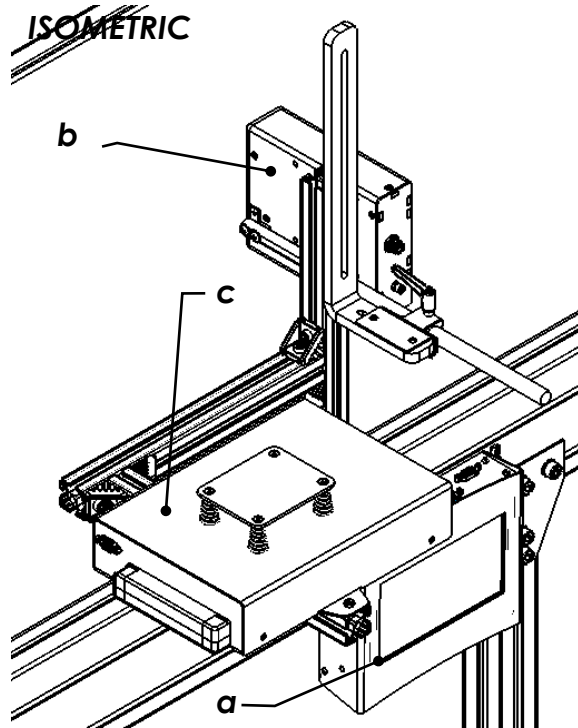

## Printhead

The print head is packed and sealed when taken out of package. To prepare for assembly it must be unsealed. Please do not use sharp tools to open the seal.

**Notice:** the print-head has been tested before product delivery and may contain certain amount of test ink. Unpack carefully as ink spillage may occur.

- Unseal protection wrap from print head.
- Loosen the nozzle mount screw and remove the nozzle protection cap as shown in Figure 4 and retain it in a safe place.

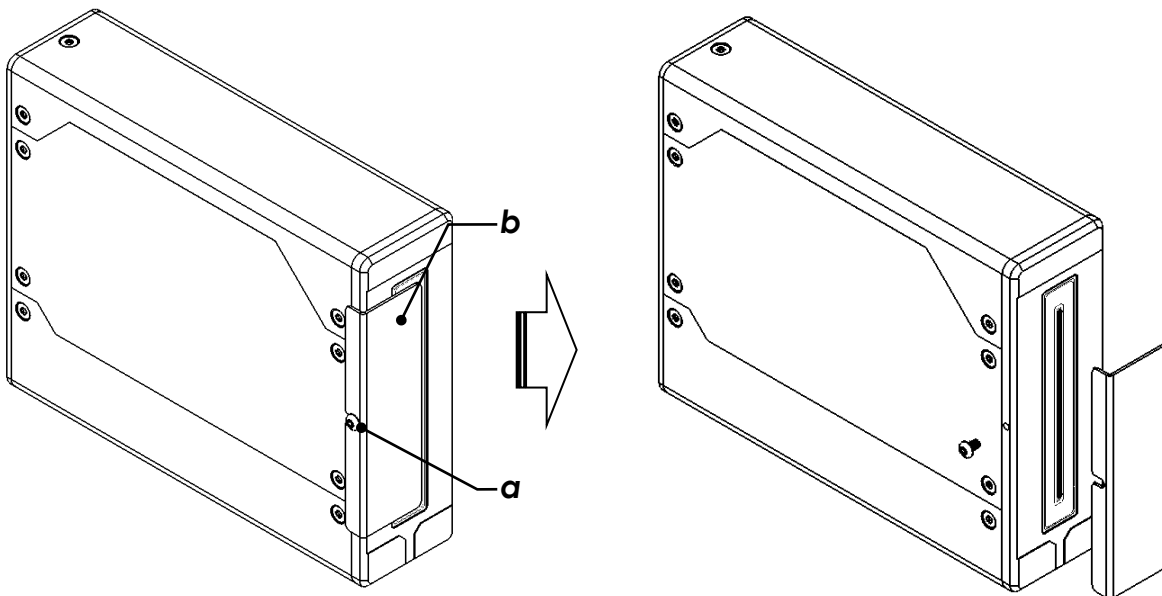

**a:** Nozzle mount protection cap

**b:** Nozzle mount Screw

Figure 4

**Notice1:** Should the printer head need to be shipped or stored, ensure that the exposed print nozzles are protected from damage. Use a lint free material, spray some cleaner solution and put it in front of nozzles, mount the print nozzle guard back and seal it using stretch wrap.

**Notice2:** If the print head is permanently connected to the controller, please do not loosen the cable glands (connectors).



## Ink System

Simply use M5/M6 screws with corresponding T-nuts to assemble them together.

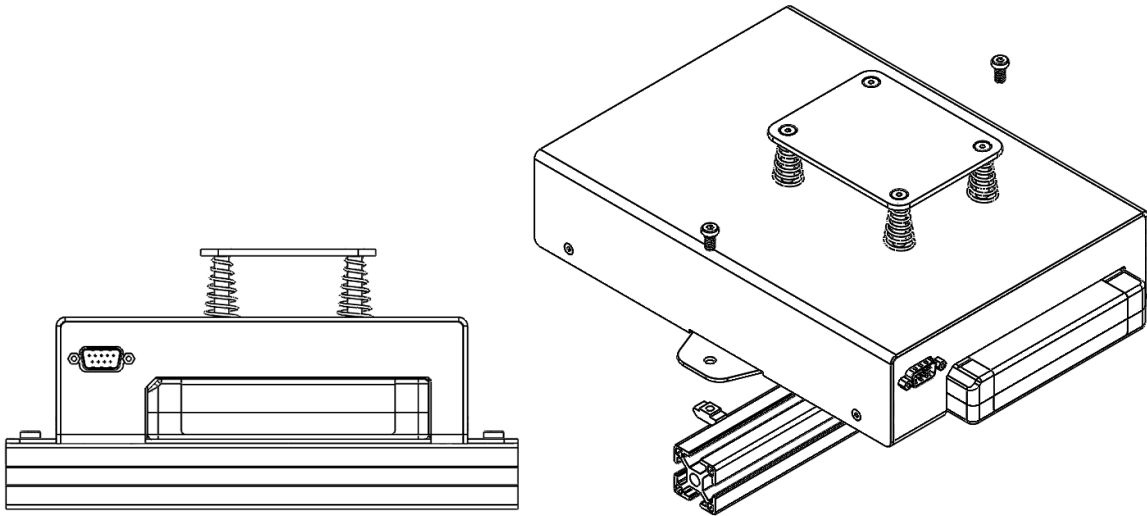

The full assembly can be mounted on the belt-conveyor as shown below.

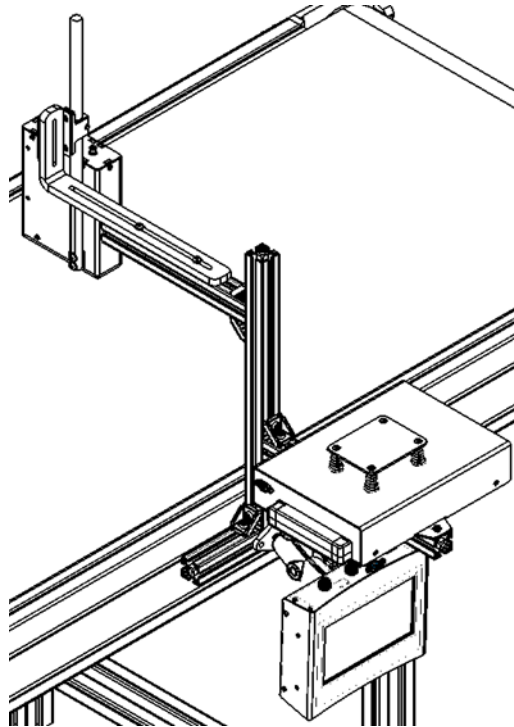
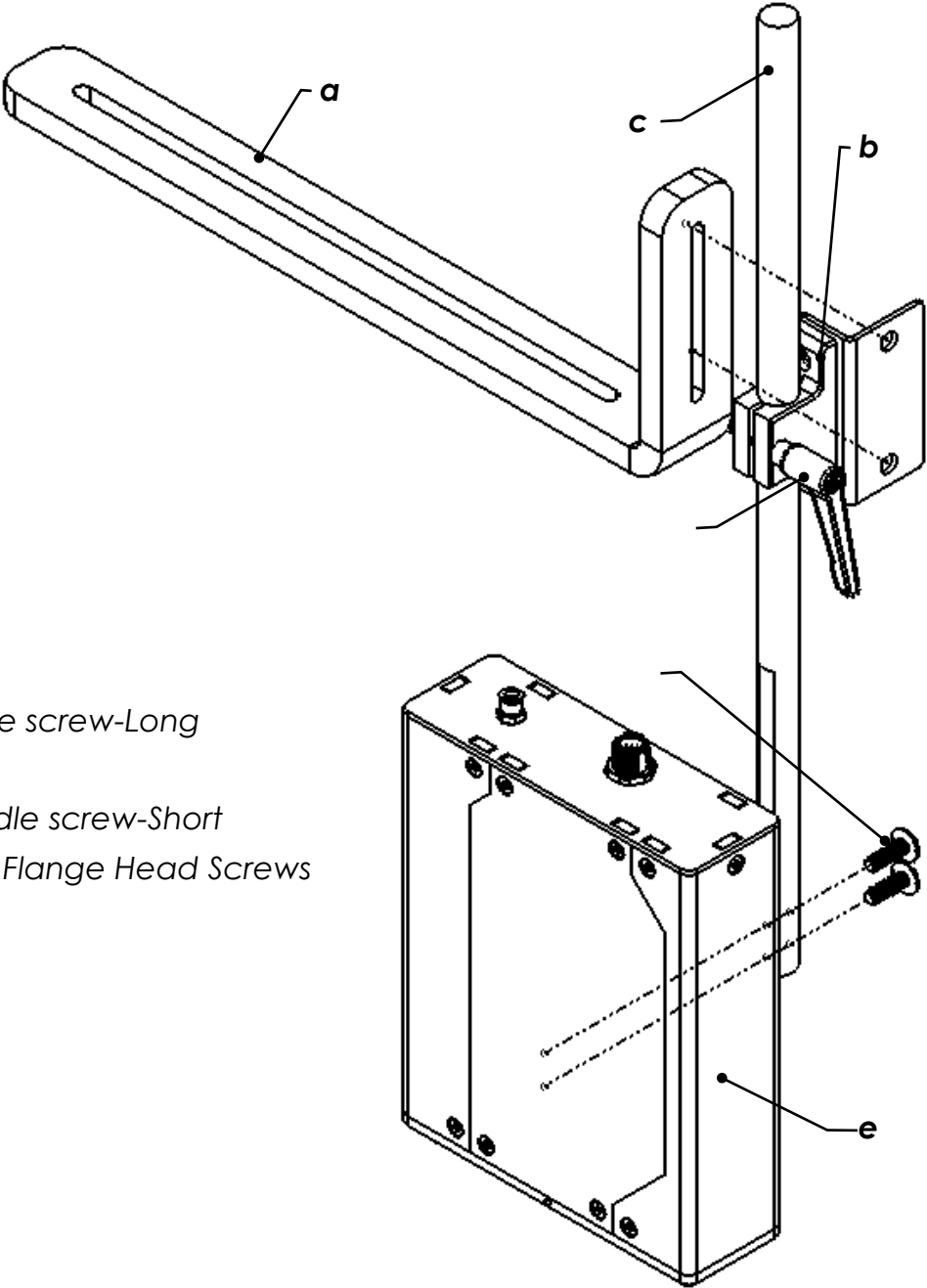

Figure 5

# L-Shape + Rod Mounts

The print head is mounted on the rod and L-shape mounts shown in Figure 6. See Section "Adjusting" for more details.



- a:** L-Shape Mount
- b:** Rod Mount
- c:** Rod
- d:** M5- Lever Handle screw-Long
- e:** Print Head
- f:** 1X M5 Lever Handle screw-Short  
OR 2X M5x16mm Flange Head Screws

Figure 6

## Ink tube

The printer head is pre-loaded with residual amount of ink which will be expelled during installation. Holding or placing an absorbent material between the printer head assembly and the conveyor is recommended at the time for set-up and mounting. Do not forget to remove it before testing and operating.

- Fasten the Filter-Needle assembly into the nut devised on the ink system (see Figure 7).

**Notice:** This is a plastic part and can be damaged if over-forced or not properly aligned.

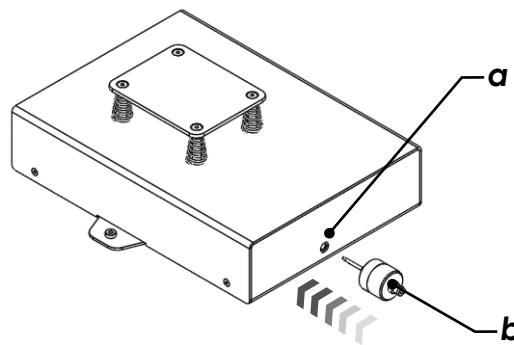

**a:** Surface mount Nut

**b:** Filter-Needle Assembly

Figure 7

- Unscrew the plastic tube cap located on back side of the print-head (see Figure 7).

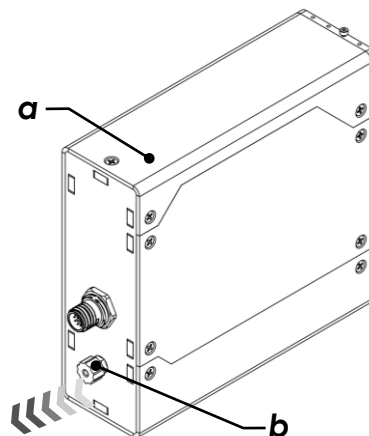

**a:** Print-head

**b:** Tube cap on print-head

Figure 8

- Insert one end of the ink supply tube in the fitting located at the back of the printhead and press firmly into place (see Figure 9).
- Connect the other end of the ink supply tube to the fitting located on back of the ink system and press firmly in place.

**Notice1:** Retain the caps for potential re-use during disassembly for storage or transport.

**Notice2:** Ink tube can be routed properly after adjusting the print head and fixing it in the desired location.

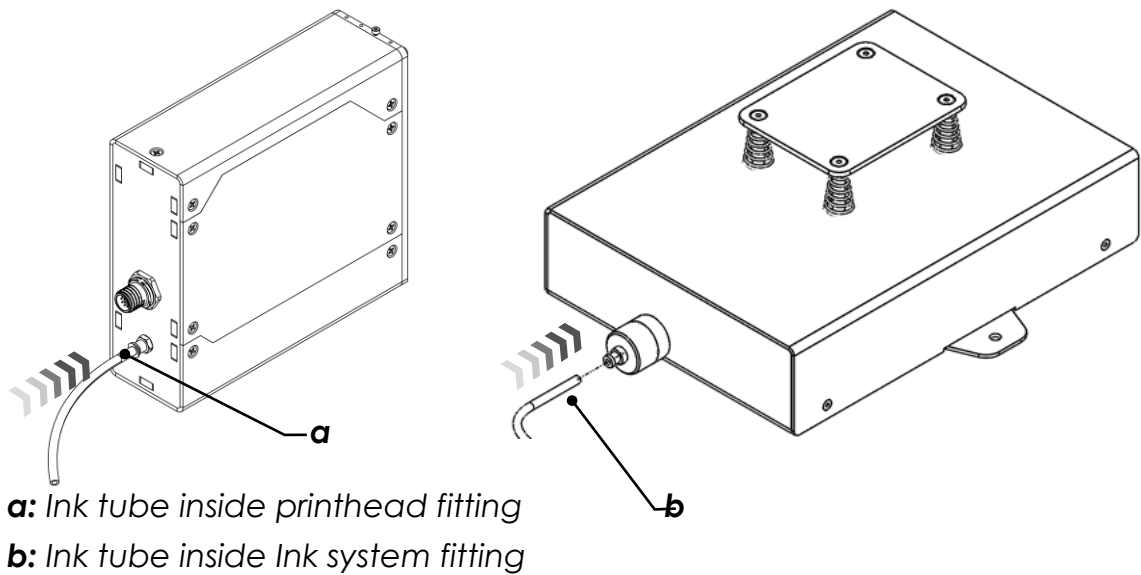

Figure 9

## Controller

According to Figure 10,

- Use 2X M4 screws to fix the controller to top pivot mount.
- Use 2X M5/M6 screws & T-nuts to fix the bottom pivot mount to the extrusion.
- Loosen the RAM mount by rotating the knob.
- Mount it to the bottom pivot mount.
- Mount the top pivot mount and controller to another side.
- Adjust the controller to the desired position.
- Firmly holding the controller and rotating the knob of the RAM mount to tighten everything up.

- a:** Controller
- b:** Top Pivot Mount
- c:** 2X M4 screws
- d:** Bottom Pivot Mount
- e:** 3030 Aluminum Extrusion
- f:** 2X M5/M6 screws & T-nuts
- g:** RAM Mount

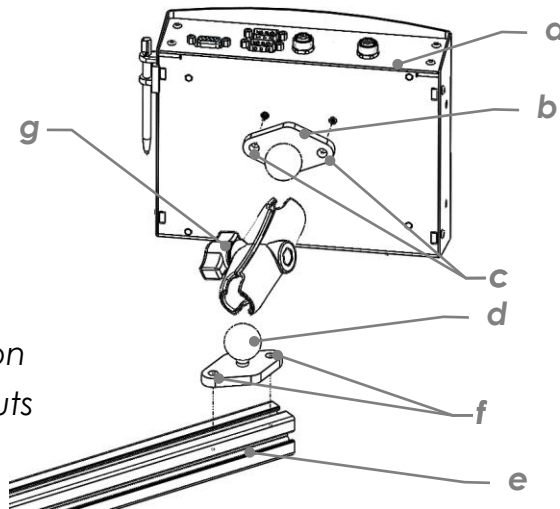

Figure 10

## Power Supply

- Insert the male end of the power adapter cable supplied at the back of printer (refer to Figure 11).
- Connect an applicable length power cord to the power adapter and plug into power source supply (single phase/120/240V AC 15 amp circuit). Avoid where possible the use of extension cords.

**Notice:** Due to different plug adaptors around the world and to avoid any misuse of connections, power cord is not provided and should be supplied locally.

- Toggle the two-position power switch to the “ON” position when printer operation is required.

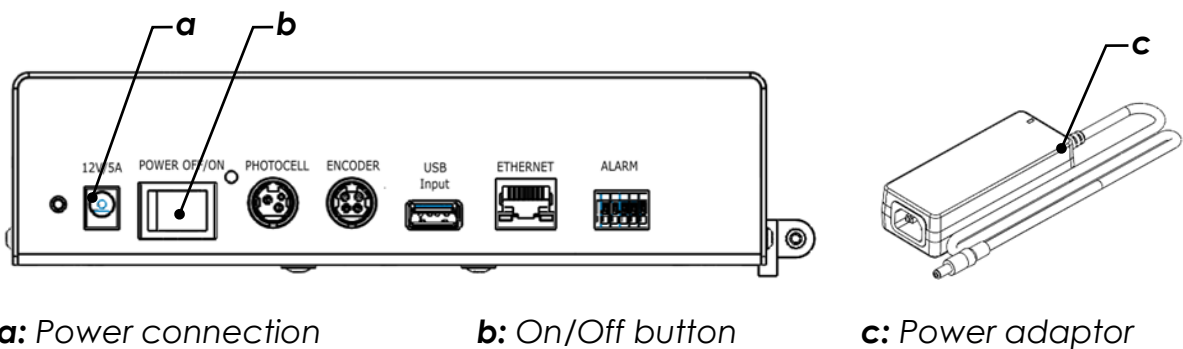

1. Fit the holding clip to the connector

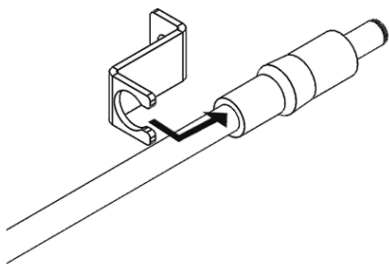

2. Plug the cable into the controller

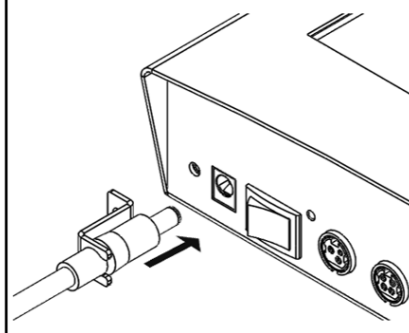

3. Fix the power cord with M3 screw

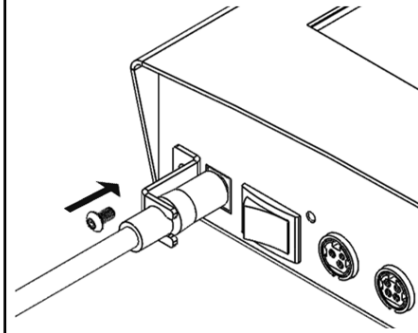

Figure 11

## Data Connections

**Notice:** DO NOT Connect/Disconnect the connectors when the power button is ON.

**Notice:** Power, data and sensor input cables must be inserted appropriately in their respective locations. Where possible, route cables away from moving objects and secure via tie-wraps.

### Photocell Sensor

For print trigger, a photocell sensor is included. Photocell sensor works as Light ON trigger. Please see Figure 12.

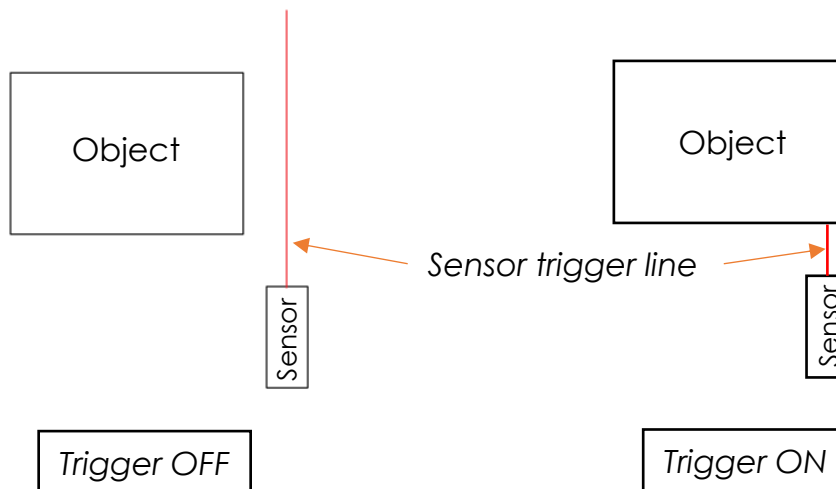

Figure 12

As shown in Figure 13, the printer system provides an NPN sensor signal input which triggers print command. It could be used with any 12 VDC NPN sensor.

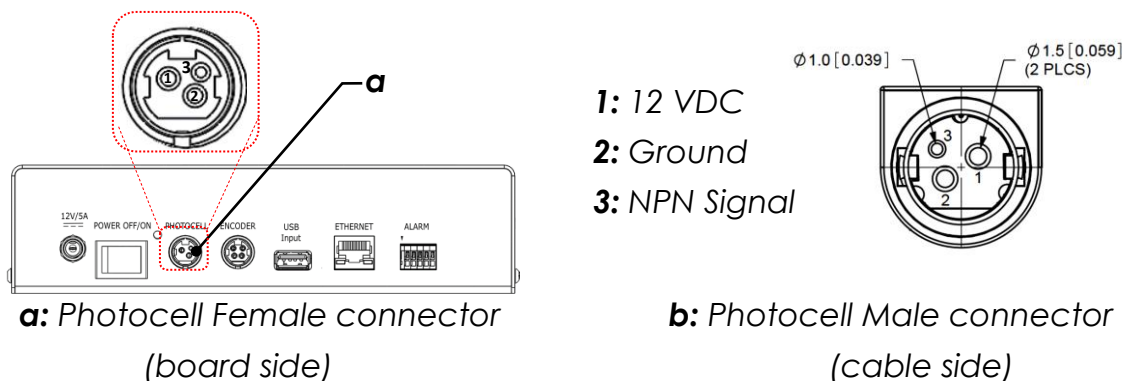

Figure 13

A Photocell sensor with proper 3-Ppin connector as well as a photocell mount bracket is included for versatile mounting on conveyor system.

**Notice:** Photocell mount can be installed on the print head using M3 screw provided on devised threaded holes, or any other desired location based on print configuration. It is recommended to install it as close to the printhead as possible.

Slide the sensor through the sensor mount and re-secure by installing one locking nut from the top and the other from the bottom as shown on Figure 14. Finger tighten both locking nuts until there is no movement between the sensor and mount.

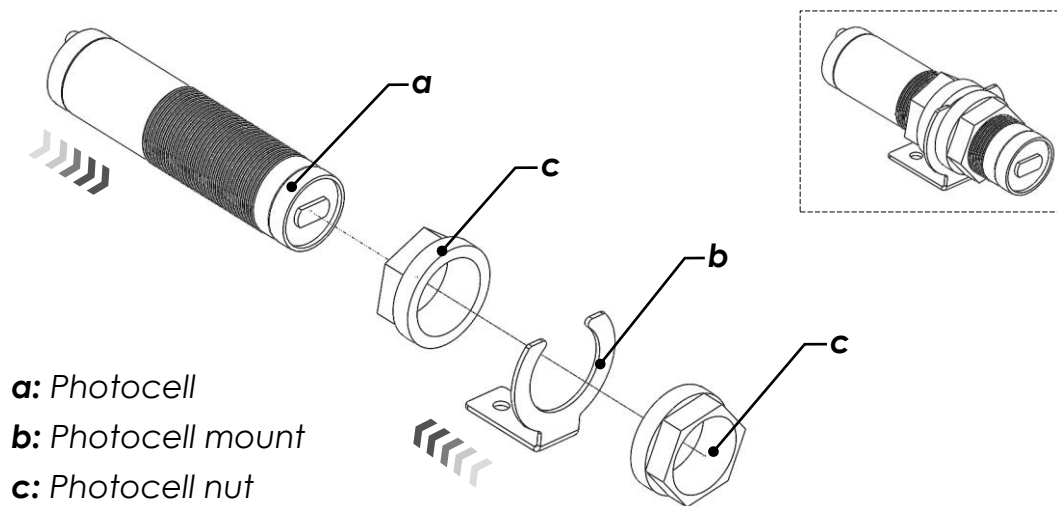
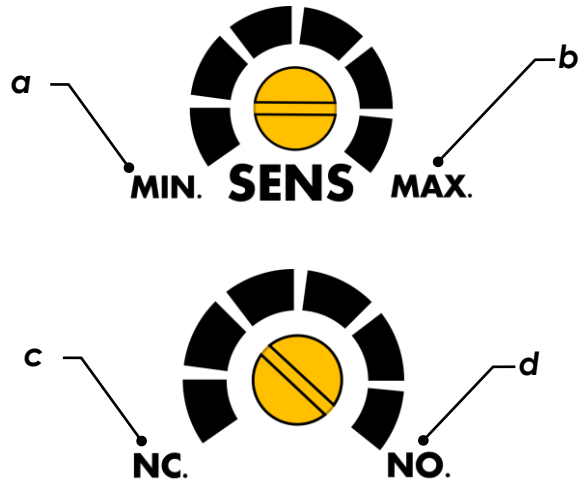

Figure 14

As shown in Figure 15, There are two settings on the photocell sensor body for adjusting sensing range (270° Potentiometer) and operating mode (2 positions).

Sensor is more sensitive to lighter colors (Highest: White) and less sensitive to darker colors (Lowest: Black). It also must be in Normally Open mode to trigger the print every time the printing substrate passes by.





- a:** Minimum Sensitivity (distance)
- b:** Maximum Sensitivity (distance)
- c:** Normally Closed Mode
- d:** Normally Open Mode

Figure 15

**Notice:** Sensor is preadjusted to Max sensitivity and Normally Open mode. Please do not touch the settings unless required otherwise.

### Shaft Encoder

Printer system is shaft encoder ready and provides a 12 VDC signal input (NPN configuration) on board which triggers print command (Figure 16). This function is available on demand. Consult your distributor for more details.

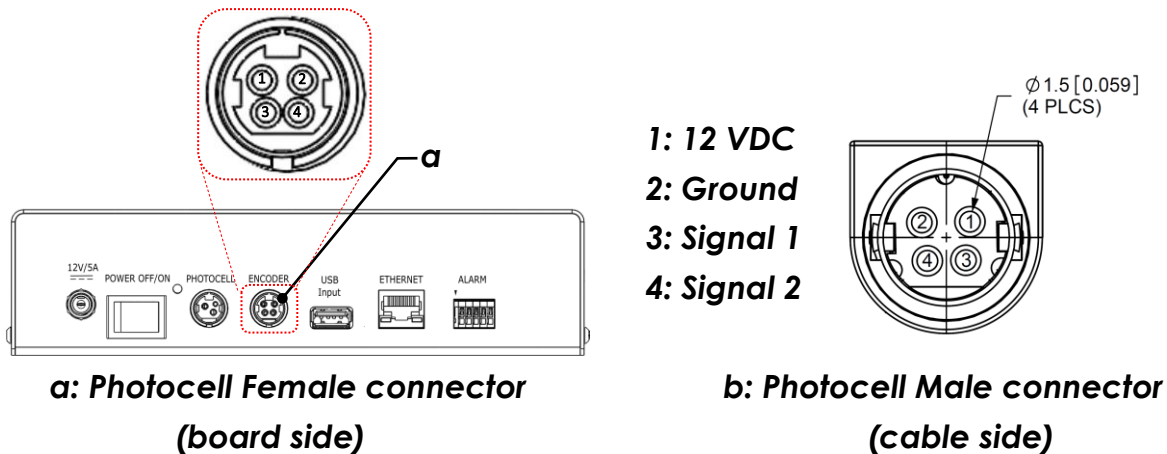

**a: Photocoil Female connector (board side)**

**b: Photocoil Male connector (cable side)**

Figure 16

The print head resolution is **R=180 DPI**. For an encoder with **N** number of pulses per revolution, Wheel Diameter **D**, is calculated by equation below:

$$D = \frac{N}{\pi R} [in] \quad \text{or} \quad D = \frac{25.4N}{\pi R} [mm]$$

The units used in the shaft diameter calculation formula for **n=1** revolution is as shown below:

$$D[in] = \frac{N [pulse/rev] \times n[rev]}{\pi R[pulse/in]} \quad \text{or} \quad D[mm] = \frac{N [pulse/rev] \times 1[rev]}{\pi R[pulse/in]} \times \frac{25.4 [mm]}{1 [in]}$$

For example, the wheel diameter for a Shaft Encoder with **N=1800 pules per revolution** is:  $D = \frac{1800 \times 1 \times 25.4}{180\pi} = 80.8mm (3.18")$

## USB

USB port is used for data uploading on typical flash drives compatible with USB2.0 connections and should not be used for any other purposes.

**Notice:** Before turning ON the machine, insert the USB in the USB connector which is located on the side of the printer

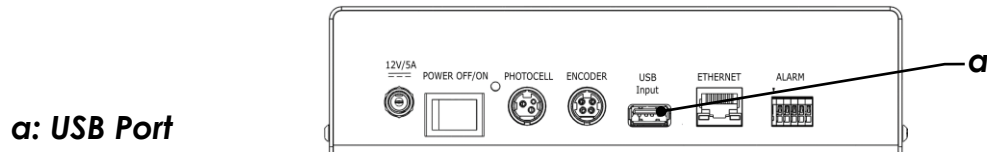

Figure 17

## Ethernet

Ethernet connection is capable of connecting print system to external controllers using IP based communication with PCs, PLCs, etc. Print system programming and message layout uploading/downloading is managed through this port.

**Notice:** For more information on print system configurations and Ethernet connection capabilities, please refer to "USER'S MANUAL" accompanied with the device.

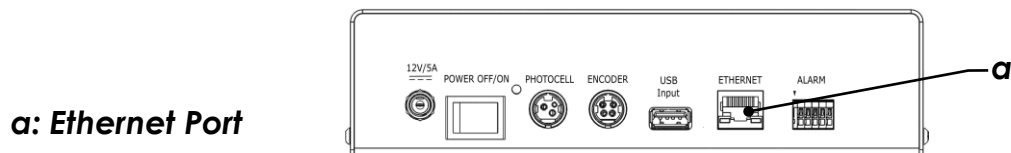

Figure 18

## External Alarm Terminal (Cartridge Ink System only)

An external beacon alarm can be connected to the alarm terminal if necessary. Pin 1 is the first terminal on the left. The pin out is indicated in Table 1.

**a: Alarm Terminal**

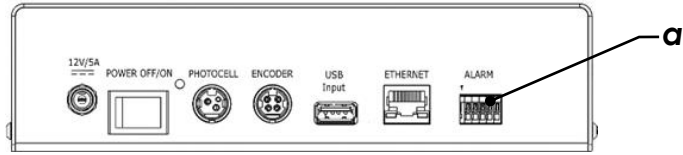

Figure 19

**Notice1:** This function is not available in H-Series.

**Notice2:** For Bulk ink system use the port on the ink system and avoid using this port.

Pin#	Color	Function
1	Green	Print ON
2	Yellow	Ink Low
3	Gray (GND)	-
4	Red	No Ink/Tag Lost
5	Reserved	-

Table 1. External Alarm Terminal Pin Out

## Ink Data

Controller communicates with ink system while printing and it would stop if this connection were lost. For RNJet 72 there is only one ink system that can be directly connected to the controller as shown in Figure 20.

**Notice:** Connect the cables provided accordingly before turning on the Printer.

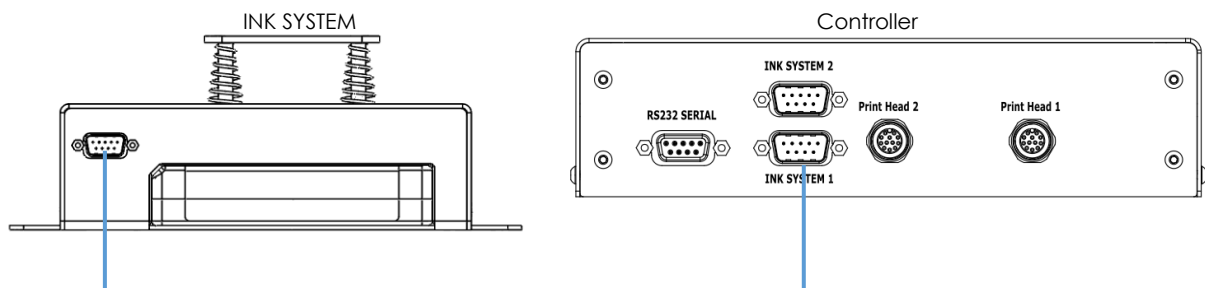

Figure 20

For RNJet 140, the second ink system should be connected to “INK SYSTEM 2” shown in Figure 20.

## Serial Port (RS-232)

RS-232 port, shown in Figure 21, is used for data communication through PLC/PC for external command/TEXT through compatible RS-232 cables and should not be used for any other purposes (for more information please refer to "USER's MANUAL" accompanied with the device).

**Notice:** Before turning ON the machine, insert the RS-232 connector which is located on the side of the printer.

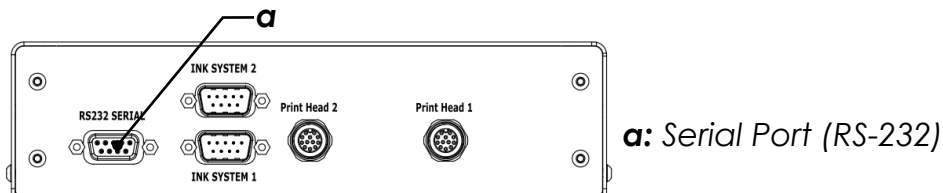

Figure 21

## Print Head Ports

Print head drivers need to be connected to the ports on the Controller (shown in Figure 22) via provided cables.

**Notice:** Connect the cables provided accordingly before turning on the Printer.

- a:** Head1 (12 PIN Female Port)
- b:** Head2 (12 PIN Female Port)
- c:** Groove

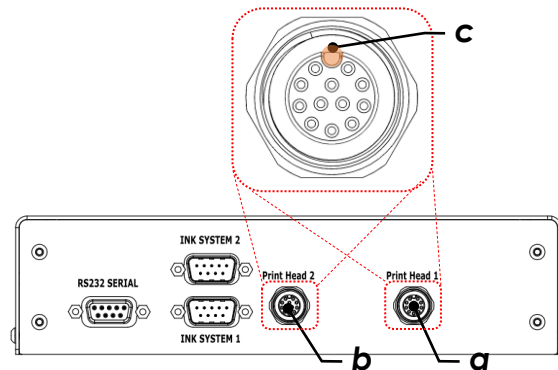

Figure 22

The ports on the controller are Female type and therefore must be connected to the Male Pin side of the cable. The plastic tongue on the cable connector must be aligned with the groove on the female connector and gently finger tighten the threaded part into the port. The arrow indicator on the connector shows the location of plastic tongue and must always be faced up.

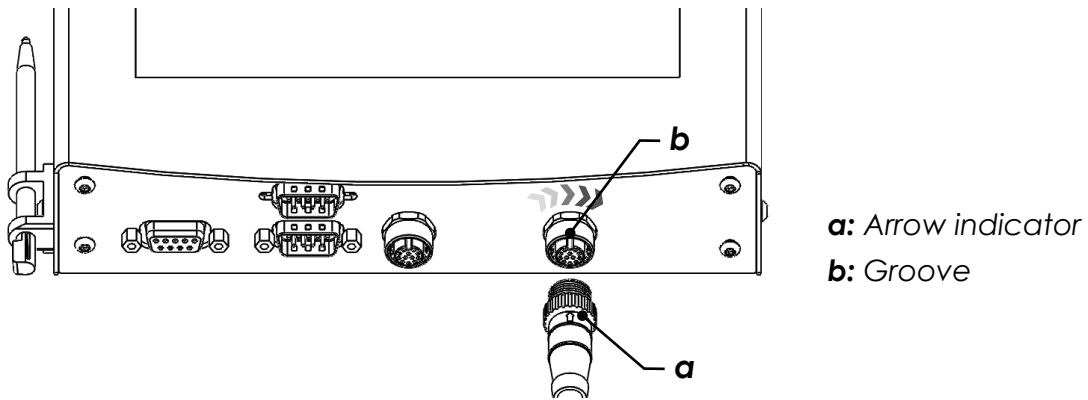

Figure 23

The other end of the cable is Round 12 Pin Female connector which also has an arrow indicator for the groove, must be aligned with the plastic tongue on the Print head port as shown in Figure 24.

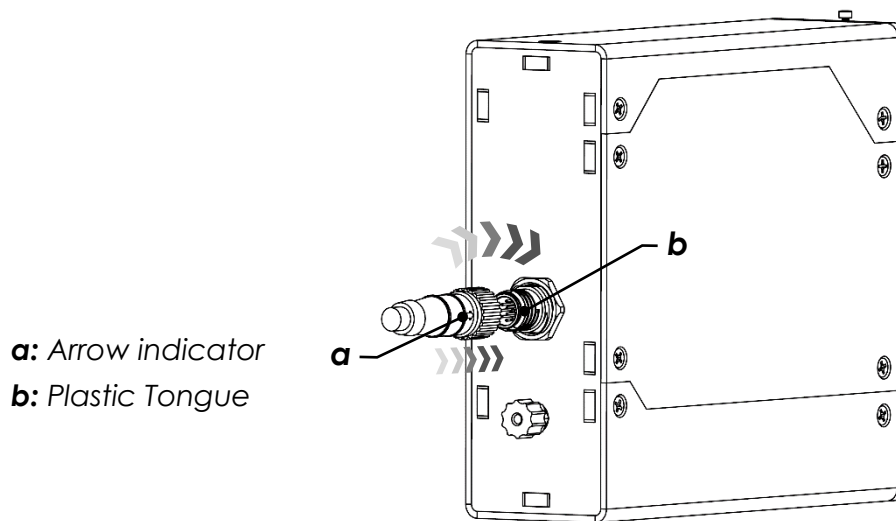

Figure 24

**Notice:** The threads on the connectors are meant to be finger-tightened and must never be over forced by wrench or mechanical tools.

# Start-up

## Adjusting

### Adjusting the Printhead

**Notice:** Adjusting the Printhead is identical for the second head. The following pictures are shown only for one head. DO NOT run conveyor during the adjustment process.

- Place a printable sample on the stopped conveyor in the approximate location where printing is to take place.
- For some applications printing surface is neither vertical nor horizontal. If it is required to print in angle fully remove one screw and loosen the other screw to release the head. Bring it to desired position and tighten the screw on the printhead assembly.

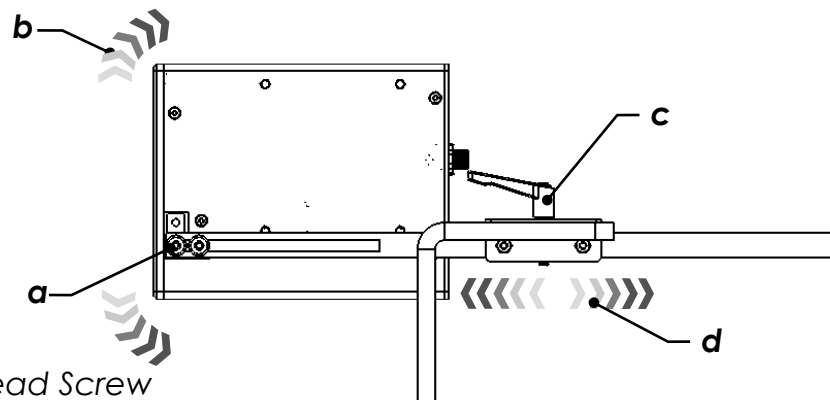

**a:** M5 x 16 mm Flange Head Screw

**b:** Swing Angle: 0° to 90°

**c:** Lever Screw

**d:** Back & Forward Movement

Figure 25

**Notice:** The ink supply system uses a gravity fed negative pressure to feed ink to the print nozzles. To maintain the optimal vacuum pressure (negative pressure) the print engine nozzle must be 40-50mm vertical distance away from the bottom of the ink supply system.

To adjust the print head and ink system levels, loosen up the L-shape's and gussets' screws and do the adjustment according to below illustration.

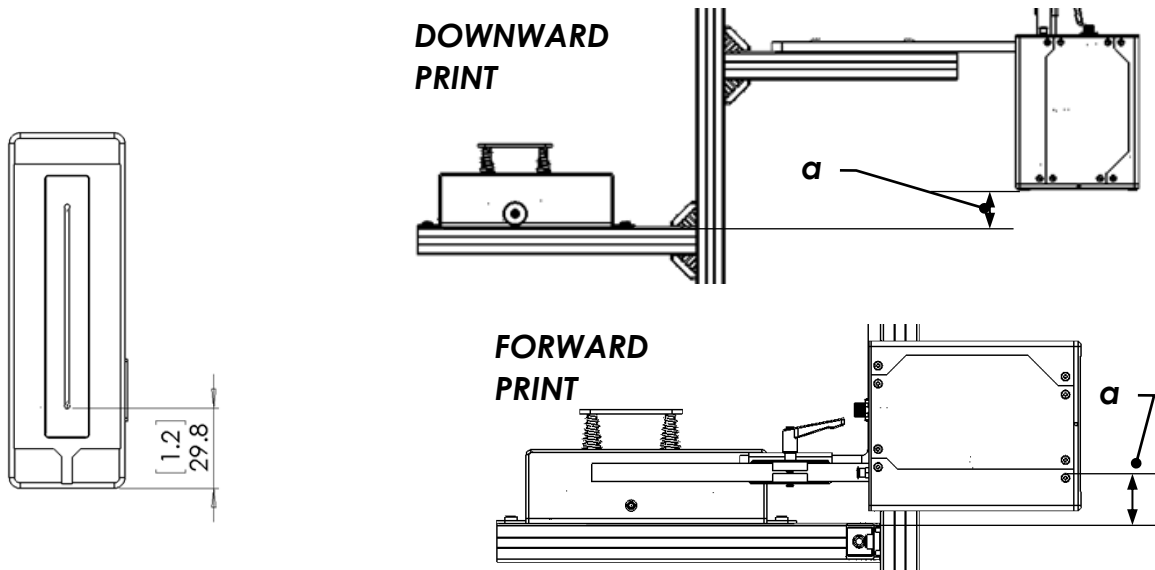

**a:** distance between lowest nozzle and bottom of ink supply

Figure 26

The **operating distance** between the exposed print nozzles on the cartridge and the desired printable surface **is 1-15mm** (see Figure 27). This may vary depending on the printing speed and operating environment conditions (see Figure 27).

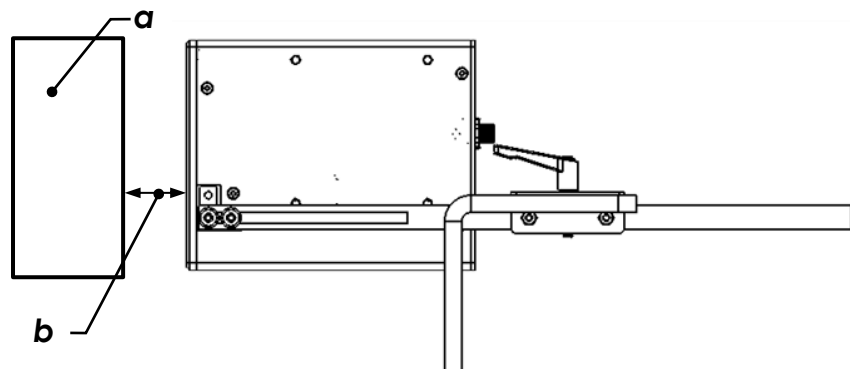

**a:** Substrate

**b:** distance between Printhead and substrate [1-15 mm]

Figure 27

**Notice:** Care must be taken to ensure that no part of the moving object comes in direct contact with the printer head assembly, clamping slider, ink supply tube or any cables or cords.

# Other Printer Head Positions

## Horizontal

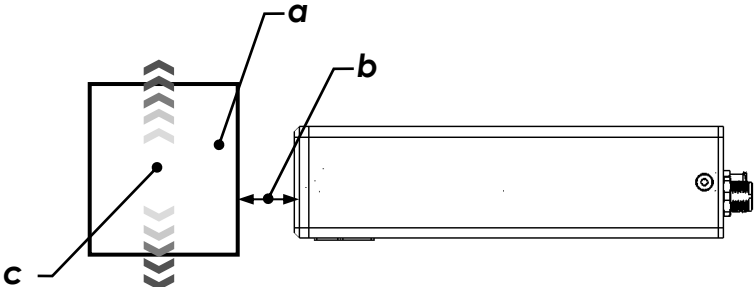

**a:** Substrate

**c:** Substrate direction of movement

**b:** distance: [1-15 mm]

Figure 28

## Downward

**Notice:** In down-shooter position, remember to wipe printer head nozzles thoroughly after purge.

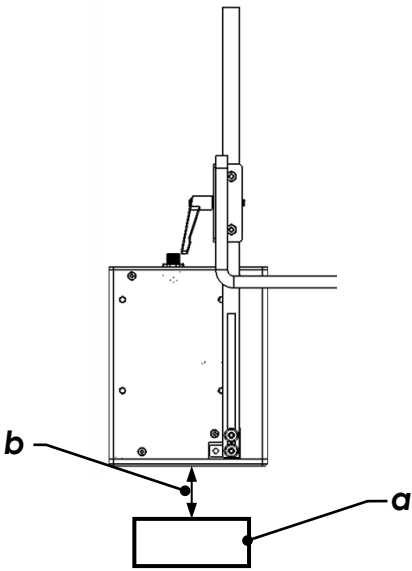

**a:** Substrate

**b:** distance: [1-15 mm]

Figure 29



## Inserting Ink cartridge

- Insert the ink cartridge into the cartridge slot located at the front of the ink supply system.
- Push the cartridge in as much as possible to ensure proper grip.
- The guiding line (red) should be slightly away from the front face of the enclosure.

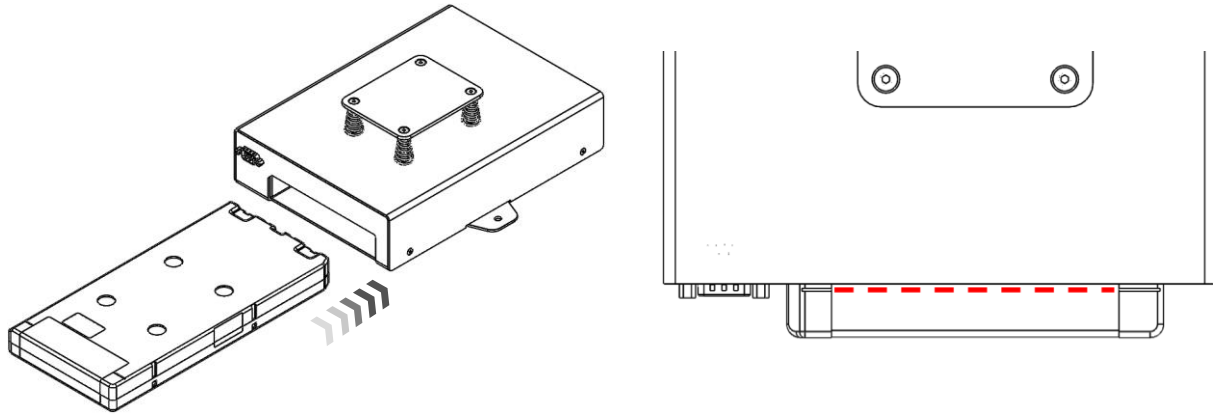

Figure 30

## Priming / Purging

The ink system must be primed and purged before every first print. It is recommended that an absorbent material be held or placed below the printer head during purging, as ink will be expelled during the purging and test printing.

- Push purge button located on the bottom of the ink cartridge through the round opening located on the underside of the ink supply unit until ink flows from the print head nozzles (see Figure 31).
- Continue to push the ink button until ink flows from printhead nozzles and no air or bubbles are visible inside the ink supply tube or the printhead.

**Notice:** The ink will gradually bleed from bottom to top of the nozzles.

- Blot or dab the print nozzle guard with an absorbent material to remove any expelled ink.

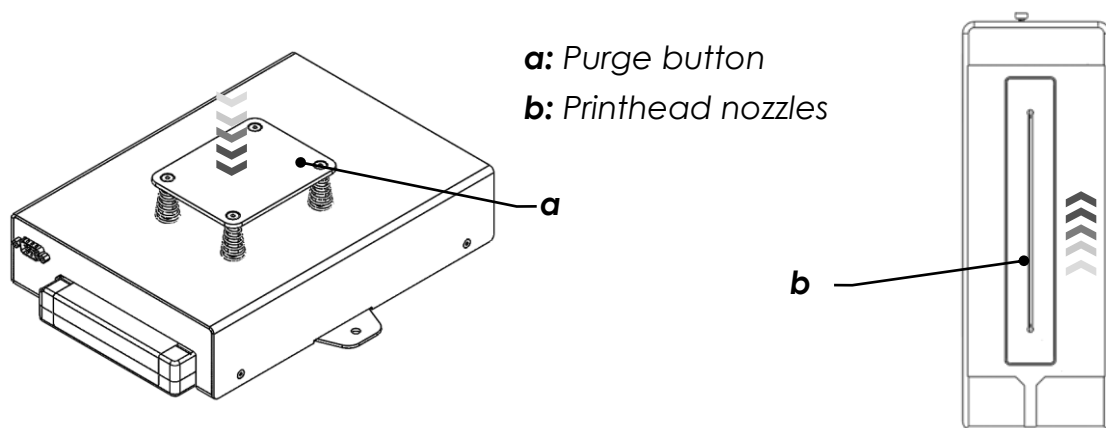

• Figure 31

# Maintenance and Services

The printer head may require cleaning and maintenance due to environmental or product debris such as dust, hair, fibers etc. Care must be taken during cleaning to ensure the exposed print nozzles are not damaged.

**Notice:** Use only *RN MARK* Spray cleaner for printhead maintenance.

## Cleaning the Printer Head

- Loosen the printer head clamping screw and adjust to expose the print nozzle cover (if required).
- Retighten clamping lever.
- Hold or place an absorbent material directly below the printer head.
- Sparingly spray the print nozzles and print nozzle cover with specially formulated **RN MARK Cleaner**.
- DO NOT RUB the print nozzle cover. If necessary, blot excess cleaning solution with an absorbent material.
- Loosen clamping screw, return the printer head to its original print position and re-tighten firmly.
- Test print sample before resuming production printing.

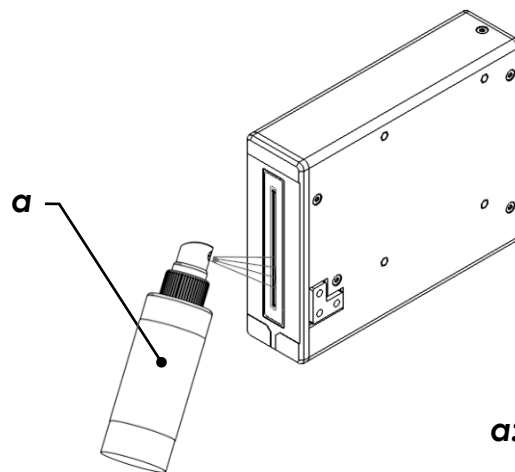

**a:** *RN MARK* Cleaning spray

Figure 32

## Flushing the Print Head

There are circumstances in which print head is required to be flushed. Please follow steps below to have a worry free and safe process (see Figure 33).

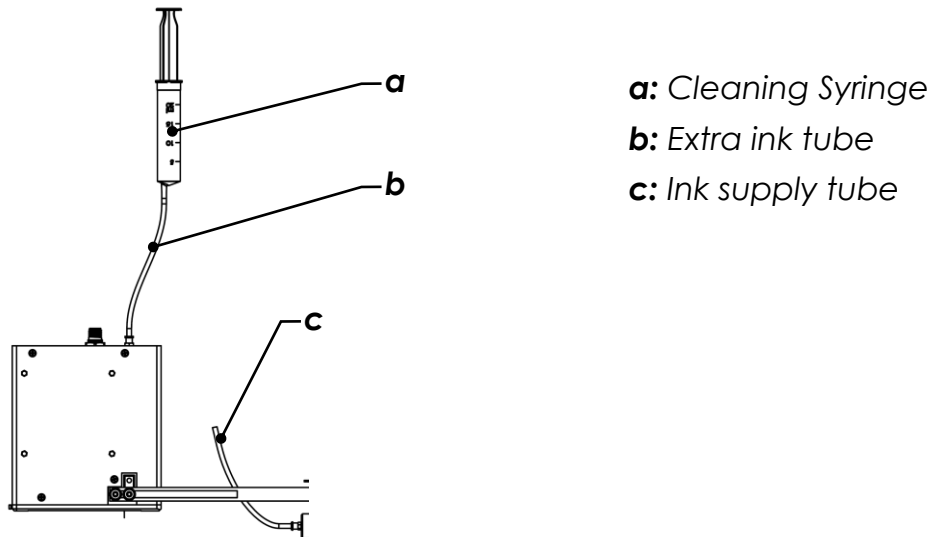

Figure 33

**Notice:** During process, the printing system must be unplugged and turned off.

1. Adjust the printer head until the connector side is horizontal/face-up.
2. Unplug the ink tube from print head and keep the tube level above the ink system to drain the remaining ink into the cartridge.
3. Remove the ink cartridge for storage or disposal.
4. Spray some cleaner on the nozzle plate to dissolve the dry ink residues on the external surface of nozzles.

**Notice:** Always hold a container under print head to avoid ink spillage in the working environment.

5. Fill the syringe with air and plug it into the ink inlet and push the piston to discharge the residual ink inside the print head as much as possible. (Repeat Two times).
6. Disconnect the syringe, draw a small amount (<20cc) of RN MARK Cleaner into it and plug it back to print head.
7. Discharge cleaner solution to wash the dye/pigment and unclog the nozzles.

8. Repeat Steps 5-7 if required.
9. Check the ink tube for residues of dried ink and replace it with a tube if necessary.
10. Plug the ink supply tube back to the print head and adjust the print head to printing position.
11. Insert the cartridge and purge until ink bleeding from all nozzles with no bubbles
12. Spray cleaner solution on the nozzles and dab the excess ink/cleaner.
13. Turn on print system and test for print quality.

**Notice:** If you are using a cleaner cartridge, follow the instruction to Step 4, insert the cleaner cartridge, and purge until you see clear solution dripping from ink tube. Plug it to the print head and purge to discharge the remaining ink. Purge 2-3 seconds more after clear solution starts to bleed from all nozzles. Take the cleaner cartridge off and follow the instructions from Step 10 forwards.

**Notice:** Never leave the print head without ink and possibly use it after flushing. If storage is required see **Storage Ink (Maintenance Ink)** section.

**Notice:** If print quality is not satisfying, contact RN Mark Technical support team for more help.

## Changing the printing ink color

There are circumstances which leads to change of ink color for printing.

If so:

- Flush the print head as instructed in previous section.
- Replace the ink supply tube with a brand new one and make sure it is fixed in position.
- Insert new cartridge with desired color.
- Purge repeatedly until the ink with new color until bleeding from all nozzles with no bubbles.
- Spray cleaner solution on the nozzles and dab the excess ink/cleaner.
- Turn on print system and test for print quality.

**Notice:** If print quality is not satisfying, try repeating purging and cleaning printhead until desirable results take place.

**Notice:** Please make sure not to confuse solvent based and oil based ink as these inks are not compatible

## Storage Ink (Maintenance Ink)

**Notice:** The storage Ink A.K.A Maintenance ink must be purchased separately.

If the solvent-based printer is supposed to be on stall for more than 10 Days, printing ink should be replaced by storage ink as described below:

- Flush the print head as instructed in previous section.
- Flush the ink tube and reconnect it to print head.
- Insert the Storage Ink cartridge and purge until storage ink (RED) bleed from all the nozzles.
- Try to print some sample messages with Maintenance Ink.
- Spray some cleaner solution on the nozzles. Fold a lint free paper towel to size of 5"x5" or 13x13 cm<sup>2</sup>. Spray some cleaner on it too.

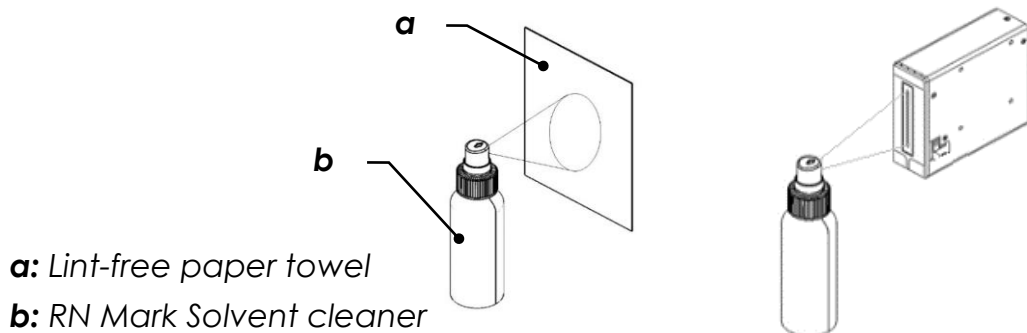

Figure 34

- Fold the sides in a way that it wraps around head and put the protection plate back. Use a stretch wrap to seal the print head airtight.

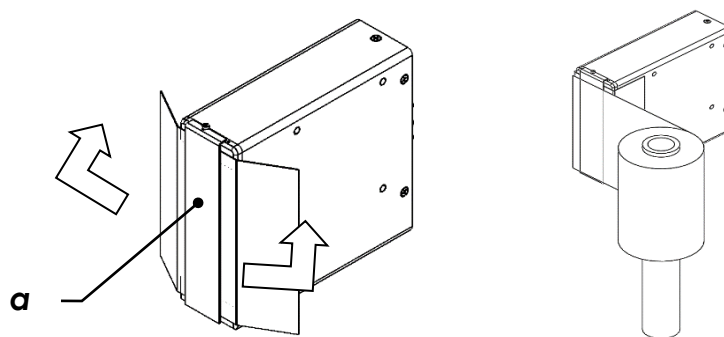

Figure 35

**Note:** Please note that this step is particularly important to keep the nozzles wet by minimizing ink evaporation to prevent clogging of the nozzles.

## Installation and Technical Support

Telephone and Whatsapp technical support is available in Canada and the U.S. Monday through Friday 9:00am to 5:00pm EST.

Toll-Free: 1 866 551 9406

Sales: 1 905 597 4977

Sales: 1 905 597 4978

Tech Sup: 1 905 597 9406

Tech Sup: 1 905 597 9406 (Whatsapp Available)

Questions and comments can also be sent to: [ts@rnmark.com](mailto:ts@rnmark.com)

[WWW.RNMARK.COM](http://WWW.RNMARK.COM)